

RF Cable & Adaptor

Data sheet (EN02A)



RF Cable & Adaptor DataSheet

RF cables and adaptors are important links in connecting the DUT and instruments. SIGLENT provides high-quality RF cables and adaptors with various materials, connector types and frequency range according to actual test requirements.

| Type | Model | Connector type | Frequency | Length(mm) | Impedance |
|-------------------|---|---|---------------|------------|-----------|
| RF Cable | N-BNC-2L | N (Male) – BNC (Male) | DC ~ 2 GHz | 700 | 50Ω |
| | N-N-6L | N (Male) – N (Male) | DC ~ 6 GHz | 700 | 50Ω |
| | N-SMA-6L | N (Male) – SMA (Male) | DC ~ 6 GHz | 700 | 50Ω |
| | S06-NMSF-1M | N (Male) – SMA (Female) | DC ~ 6 GHz | 1000 | 50Ω |
| | N-N-18L | N (Male) – N (Male) | DC ~ 18 GHz | 1000 | 50Ω |
| | N-SMA-18L | N (Male) – SMA (Male) | DC ~ 18 GHz | 1000 | 50Ω |
| | S18-NMSF-1M | N (Male) – SMA (Female) | DC ~ 18 GHz | 1000 | 50Ω |
| | SMA-SMA-18L | SMA (Male) – SMA (Male) | DC ~ 18 GHz | 1000 | 50Ω |
| | SMA-SMA-26L | SMA (Male) – SMA (Male) | DC ~ 26.5 GHz | 1000 | 50Ω |
| | SMAF-SMA-26L | SMA (Male) – SMA (Female) | DC ~ 26.5 GHz | 1000 | 50Ω |
| | V26-N35MN35F-25IN | NMD 3.5 mm (Female) – NMD 3.5 mm (Male) | DC ~ 26.5 GHz | 635 | 50Ω |
| | V26-N35FA35F-25IN | NMD 3.5 mm (Female) – APC 3.5 mm (Female) | DC ~ 26.5 GHz | 635 | 50Ω |
| | S40-29M29F-1M | 2.92 mm (Male) – 2.92 mm (Female) | DC ~ 40 GHz | 1000 | 50Ω |
| | V50-N24MN24F-25IN | NMD 2.4 mm (Female) – NMD 2.4 mm (Male) | DC ~ 50 GHz | 635 | 50Ω |
| V50-N24FA24F-25IN | NMD 2.4 mm (Female) – APC 2.4 mm (Female) | DC ~ 50 GHz | 635 | 50Ω | |
| Adaptor | 2.92F-2.92F-40A | 2.92mm (Female) – 2.92mm (Female) | DC ~ 40 GHz | | 50Ω |
| | 1.85F-2.92F-40A | 1.85 mm (Female) – 2.92mm (Female) | DC ~ 40 GHz | | 50Ω |
| | 1.85F-1.85F-67A | 1.85 mm (Female) – 1.85mm (Female) | DC ~ 67 GHz | | 50Ω |
| Utility Kit | UkitSSA3X | N(M)-SMA(M) Cable | DC ~ 6 GHz | 700 | 50Ω |
| | | N(M)-N(M) Cable | DC ~ 6 GHz | 700 | 50Ω |
| | | N(M)-BNC(F) Adaptor x2 | DC ~ 2 GHz | | 50Ω |
| | | N(M)-SMA(F) Adaptor x2 | DC ~ 6 GHz | | 50Ω |
| | | N-N 10 dB 1W Attenuator | DC ~ 6 GHz | | 50Ω |

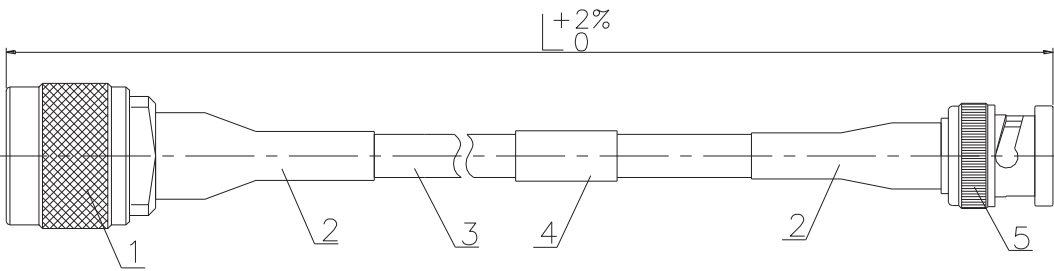
| Model | | N-BNC-2L |
|--|---|---|
|  | | |
| Parts | | |
| L | - | Cable length (L=0.7M) |
| 1 | - | N Male connector (nickel plated copper) |
| 2 | - | High temperature Shrinking tube |
| 3 | - | RG223 cable (outer diameter 5.3 mm) |
| 4 | - | Tag |
| 5 | - | BNC Male connector (nickel plated copper) |
| Specifications | | |
| Frequency | | DC ~ 2 GHz |
| Impedance | | 50 Ω |
| VSWR | | ≤1.20@DC~2GHz |
| Insertion loss | | ≤1.0dB@2GHz |
| Dielectric withstand voltage | | ≥1000V |
| Insulation resistance | | ≥5000MΩ |
| Minimum bending radius | | 25mm |
| Temperature range(Operation) | | -55℃~+85℃ |
| Length | | 700 mm |
| Package and storage | | |
| <p>The connector is encapsulated with a special dust cap. When the components are bent and packaged, the bending radius should not be less than 5 times the minimum bending radius of the cable.</p> <p>The storage conditions of the product are: -10℃~+40℃, the relative humidity is not more than 80%, and the surrounding air is free from acidic, alkaline and other corrosive gases.</p> | | |

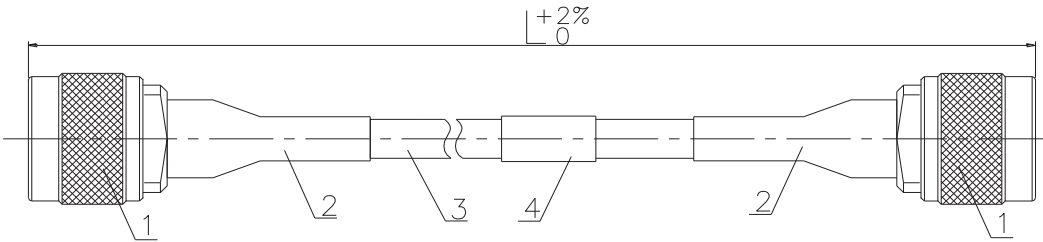
| Model | | N-N-6L |
|--|---|---|
|  | | |
| Parts | | |
| L | - | Cable length (L=0.7M) |
| 1 | - | N Male connector (nickel plated copper) |
| 2 | - | High temperature Shrinking tube |
| 3 | - | RG223 cable (outer diameter 5.3 mm) |
| 4 | - | Tag |
| Specifications | | |
| Frequency | | DC ~ 6 GHz |
| Impedance | | 50 Ω |
| VSWR | | ≤1.25:1@6GHz |
| Insertion loss | | ≤1.8dB@6GHz |
| Dielectric withstand voltage | | ≥1000V |
| Insulation resistance | | ≥5000MΩ |
| Minimum bending radius | | 25mm |
| Temperature range(Operation) | | -55℃ ~ +85℃ |
| Length | | 700 mm |
| Package and storage | | |
| <p>The connector is encapsulated with a special dust cap. When the components are bent and packaged, the bending radius should not be less than 5 times the minimum bending radius of the cable.</p> <p>The storage conditions of the product are: -10℃ ~ +40℃, the relative humidity is not more than 80%, and the surrounding air is free from acidic, alkaline and other corrosive gases.</p> | | |

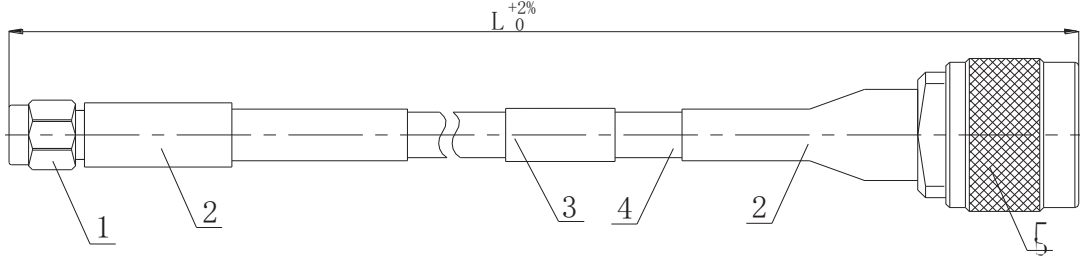
| Model | | N-SMA-6L |
|--|---|---|
|  | | |
| Parts | | |
| L | - | Cable length (L=0.7M) |
| 1 | - | SMA Male connector (nickel plated gold) |
| 2 | - | High temperature Shrinking tube |
| 3 | - | RG223 cable (outer diameter 5.3 mm) |
| 4 | - | Tag |
| 5 | - | N Male connector (nickel plated copper) |
| Specifications | | |
| Frequency | | DC ~ 6 GHz |
| Impedance | | 50 Ω |
| VSWR | | ≤1.25:1@6GHz |
| Insertion loss | | ≤1.8dB@6GHz |
| Dielectric withstand voltage | | ≥1000V |
| Insulation resistance | | ≥5000MΩ |
| Minimum bending radius | | 25mm |
| Temperature range(Operation) | | -55℃ ~ +85℃ |
| Length | | 700 mm |
| Package and storage | | |
| <p>The connector is encapsulated with a special dust cap. When the components are bent and packaged, the bending radius should not be less than 5 times the minimum bending radius of the cable.</p> <p>The storage conditions of the product are: -10℃ ~ +40℃, the relative humidity is not more than 80%, and the surrounding air is free from acidic, alkaline and other corrosive gases.</p> | | |

| | |
|--------------|--------------------|
| Model | S06-NMSF-1M |
|--------------|--------------------|

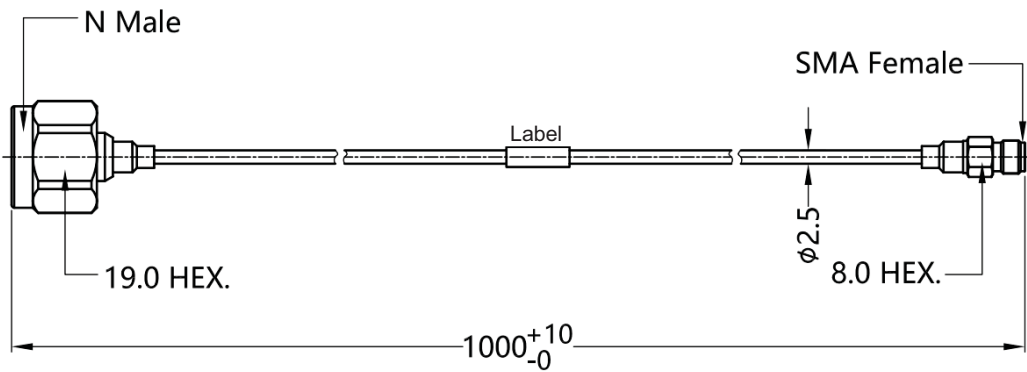

All dimensions are in millimeters tolerances

Parts

| | |
|-------------|---|
| Connector 1 | N Male |
| Connector 2 | SMA Female |
| Cable | FS-6134, Ultra Low Loss Phase Stable Coax Cable (MCC TPE) |

Specifications

| | |
|---------------------------------|------------------|
| Frequency | DC ~ 6 GHz |
| Impedance | 50 Ω |
| VSWR | ≤1.30 @DC~6GHz |
| Insertion loss | ≤2.30dB @DC~6GHz |
| Voltage rating | 335V (rms) |
| Dielectric withstanding voltage | 500V (DC) |
| Insulation resistance | 500MΩ |
| Minimum bending radius static | 13 mm |
| Minimum bending radius dynamic | 25 mm |
| Recommended coupling torque | 7-10 in-lbs |
| Coupling nut retention force | ≥60 lbs |
| Durability | ≥500 cycles |
| Temperature range(Operation) | -40℃ ~ +85℃ |
| RoHS & REACH | compliant |

Package and storage

The connector is encapsulated with a special dust cap. When the components are bent and packaged, the bending radius should not be less than 5 times the minimum bending radius of the cable.

The storage conditions of the product are: -10℃ ~ +40℃, the relative humidity is not more than 80%, and the surrounding air is free from acidic, alkaline and other corrosive gases.

| | |
|--------------|----------------|
| Model | N-N-18L |
|--------------|----------------|

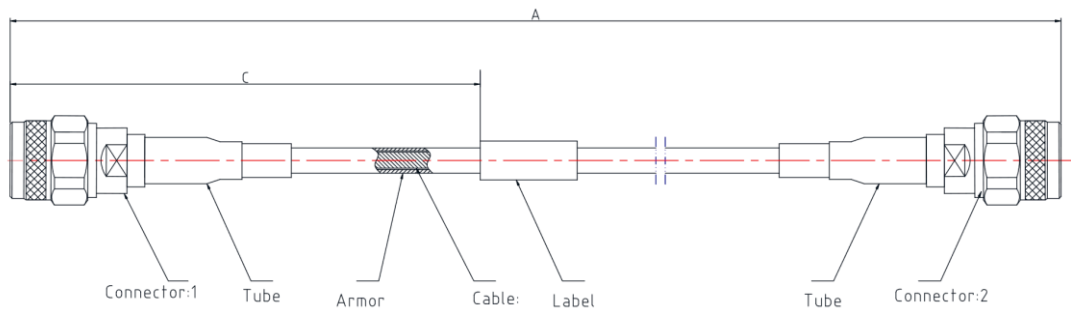

All dimensions are in mm; tolerances according to ISO 2768 c

Parts

| | |
|-------------|---|
| Connector 1 | N Male |
| Connector 2 | N Male |
| Cable | RTK Flex 402-YB Low IL(or equivalent type) |
| Label | Label Stick |
| Tube | High temperature Shrinking tube |
| Armor | Stainless steel interlocked hose with PTFE wire(black+red) jacket |

Nominal values @20°C ambient temperature

Specifications

| | |
|---------------------------------|--|
| Frequency | DC ~ 18 GHz |
| Impedance | 50 Ω |
| VSWR | ≤1.35 to 18 GHz |
| Insertion loss | ≤2.3dB@DC~18GHz |
| Phase stability vs. Flexure | ≤±10°@18 GHz (Wrapped around a 50mm diameter mandrel) |
| Amplitude stability vs. Flexure | ≤±0.1 dB@18 GHz (Wrapped around a 50mm diameter mandrel) |
| Minimum bending radius | 50.8 mm |
| Cable Diameter(with armor) | 6.6 mm |
| Temperature range(Operation) | -40°C ~ +125°C |
| RoHS | compliant |
| Length A | 1000±10 mm |
| Length C | 100±10 mm |

Package and storage

The connector is encapsulated with a special dust cap. When the components are bent and packaged, the bending radius should not be less than 5 times the minimum bending radius of the cable.

The storage conditions of the product are: -10°C ~ +40°C, the relative humidity is not more than 80%, and the surrounding air is free from acidic, alkaline and other corrosive gases.

| | |
|--------------|------------------|
| Model | N-SMA-18L |
|--------------|------------------|

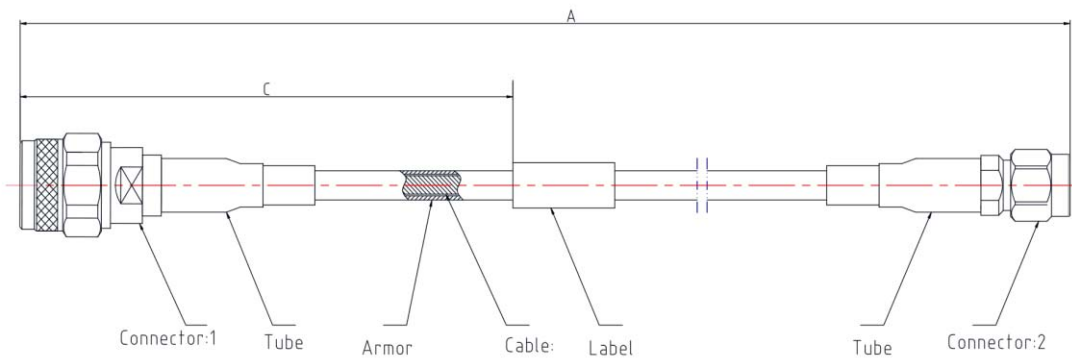

All dimensions are in mm; tolerances according to ISO 2768 c

Parts

| | |
|-------------|---|
| Connector 1 | N Male |
| Connector 2 | SMA male |
| Cable | RTK Flex 402-YB Low IL(or equivalent type) |
| Label | Label Stick |
| Tube | High temperature Shrinking tube |
| Armor | Stainless steel interlocked hose with PTFE wire(black+red) jacket |

Nominal values @20°C ambient temperature

Specifications

| | |
|---------------------------------|---|
| Frequency | DC ~ 18 GHz |
| Impedance | 50 Ω |
| VSWR | ≤1.35 to 18 GHz |
| Insertion loss | ≤2.3dB@DC~18GHz |
| Phase stability vs. Flexure | ±10°@18 GHz (Wrapped around a 50mm diameter mandrel) |
| Amplitude stability vs. Flexure | ±0.1 dB@18 GHz (Wrapped around a 50mm diameter mandrel) |
| Minimum bending radius | 50.8 mm |
| Cable Diameter(with armor) | 6.6 mm |
| Temperature range(Operation) | -40°C ~ +125°C |
| RoHS | compliant |
| Length A | 1000±10 mm |
| Length C | 100±10 mm |

Package and storage

The connector is encapsulated with a special dust cap. When the components are bent and packaged, the bending radius should not be less than 5 times the minimum bending radius of the cable.

The storage conditions of the product are: -10°C ~ +40°C, the relative humidity is not more than 80%, and the surrounding air is free from acidic, alkaline and other corrosive gases.

| Model | S18-NMSF-1M |
|-------|-------------|
|-------|-------------|

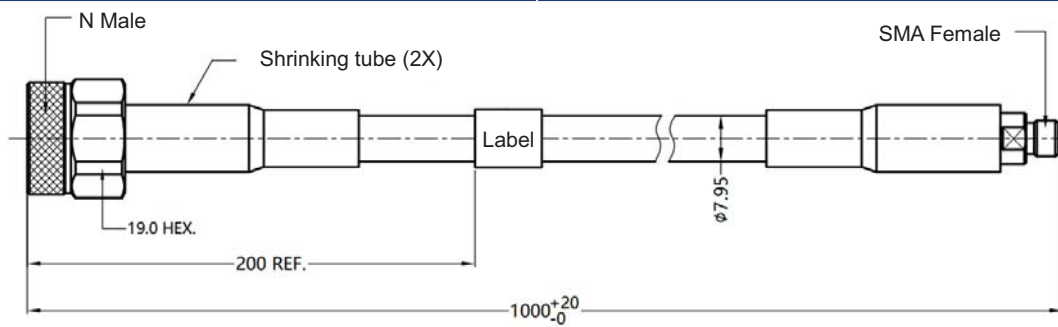

All dimensions are in millimeters tolerances

| Parts | |
|-------------|--|
| Connector 1 | N Male |
| Connector 2 | SMA Female |
| Cable | FSB500PK, Armored low pass phase stable rf cable (Black+Red) |

| Specifications | |
|---------------------------------|---------------------------------|
| Frequency | DC ~ 18 GHz |
| Impedance | 50 Ω |
| VSWR | ≤ 1.30 @DC~18GHz |
| Insertion loss | ≤ 1.56 dB @DC~18GHz |
| Voltage rating | 335V (rms) |
| Dielectric withstanding voltage | 750V (DC) |
| Insulation resistance | 3000M Ω |
| Mechanical phase stability | $\pm 6^\circ$ |
| Mechanical amplitude stability | ± 0.08 dB |
| Minimum bending radius static | 40 mm |
| Minimum bending radius dynamic | 80 mm |
| Recommended coupling torque | 7-9 in-lbs |
| Coupling nut retention force | ≥ 60 lbs |
| Durability | ≥ 500 cycles |
| Temperature range(Operation) | -40 $^\circ$ C ~ +85 $^\circ$ C |
| RoHS & REACH | compliant |

| Package and storage |
|---------------------|
|---------------------|

The connector is encapsulated with a special dust cap. When the components are bent and packaged, the bending radius should not be less than 5 times the minimum bending radius of the cable.

The storage conditions of the product are: -10 $^\circ$ C ~ +40 $^\circ$ C, the relative humidity is not more than 80%, and the surrounding air is free from acidic, alkaline and other corrosive gases.

| | |
|--------------|--------------------|
| Model | SMA-SMA-18L |
|--------------|--------------------|

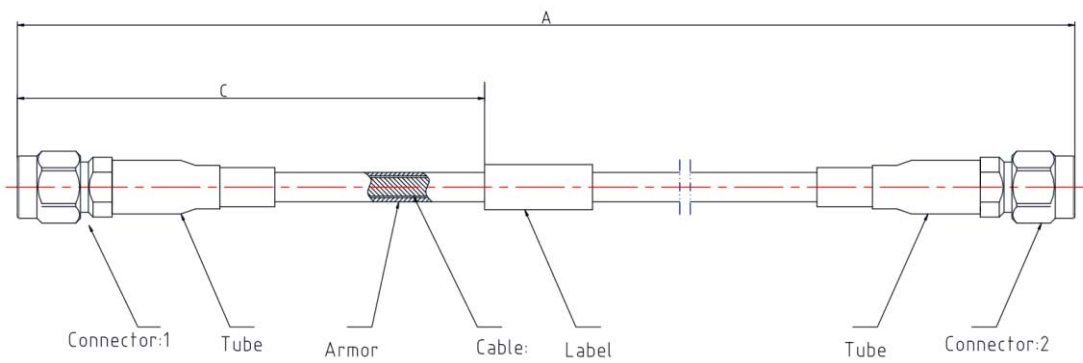

All dimensions are in mm; tolerances according to ISO 2768 c

Parts

| | |
|-------------|---|
| Connector 1 | SMA Male |
| Connector 2 | SMA Male |
| Cable | RTK Flex 402-YB Low IL(or equivalent type) |
| Label | Label Stick |
| Tube | High temperature Shrinking tube |
| Armor | Stainless steel interlocked hose with PTFE wire(black+red) jacket |

Nominal values @20°C ambient temperature

Specifications

| | |
|---------------------------------|---|
| Frequency | DC ~ 18 GHz |
| Impedance | 50 Ω |
| VSWR | ≤1.25 to 18 GHz |
| Insertion loss | ≤2.3dB@DC~18GHz |
| Phase stability vs. Flexure | ±10°@18 GHz (Wrapped around a 50mm diameter mandrel) |
| Amplitude stability vs. Flexure | ±0.1 dB@18 GHz (Wrapped around a 50mm diameter mandrel) |
| Minimum bending radius | 50.8 mm |
| Cable Diameter(with armor) | 7.7 mm |
| Temperature range(Operation) | -40°C ~ +125°C |
| RoHS | compliant |
| Length A | 1000±10 mm |
| Length C | 100±10 mm |

Package and storage

The connector is encapsulated with a special dust cap. When the components are bent and packaged, the bending radius should not be less than 5 times the minimum bending radius of the cable.

The storage conditions of the product are: -10°C ~ +40°C, the relative humidity is not more than 80%, and the surrounding air is free from acidic, alkaline and other corrosive gases.

| | |
|--------------|--------------------|
| Model | SMA-SMA-26L |
|--------------|--------------------|

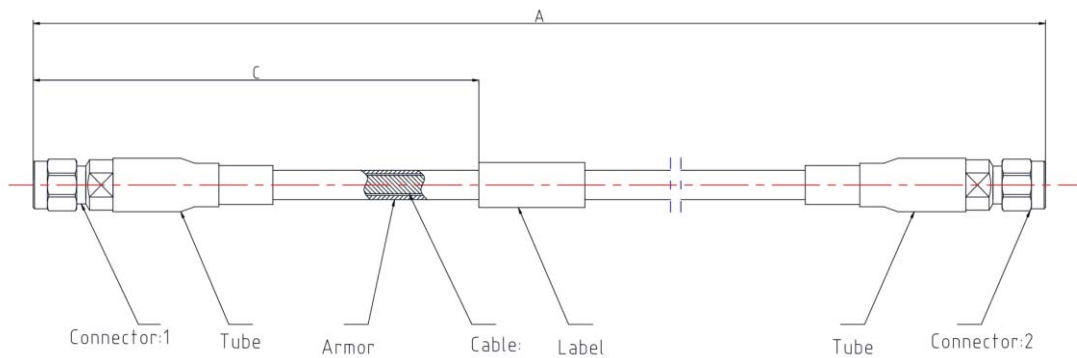

All dimensions are in mm; tolerances according to ISO 2768 c

| Parts | |
|--------------|--|
|--------------|--|

| | |
|-------------|---|
| Connector 1 | SMA Male |
| Connector 2 | SMA Male |
| Cable | RTK Flex 402-YB Low IL(or equivalent type) |
| Label | Label Stick |
| Tube | Shrinking tube |
| Armor | Stainless steel interlocked hose with PTFE wire(black+red) jacket |

| Specifications | |
|-----------------------|--|
|-----------------------|--|

| | |
|---------------------------------|--|
| Frequency | DC ~ 26.5 GHz |
| Impedance | 50 Ω |
| VSWR | ≤1.3 to 26.5 GHz |
| Insertion loss | ≤2.0 dB@DC~18 GHz |
| Phase stability vs. Flexure | ≤±8°@26.5 GHz (Wrapped around a 50mm diameter mandrel) |
| Amplitude stability vs. Flexure | ≤±0.2 dB@26.5 GHz (Wrapped around a 50mm diameter mandrel) |
| Minimum bending radius | 50.8 mm |
| Cable Diameter(with armor) | 7.7 mm |
| Temperature range(Operation) | -40°C ~ +100°C |
| RoHS | compliant |
| Length A | 1000±10 mm |
| Length C | 200±10 mm |

| Package and storage |
|----------------------------|
|----------------------------|

The connector is encapsulated with a special dust cap. When the components are bent and packaged, the bending radius should not be less than 5 times the minimum bending radius of the cable.

The storage conditions of the product are: -10°C ~ +40°C, the relative humidity is not more than 80%, and the surrounding air is free from acidic, alkaline and other corrosive gases.

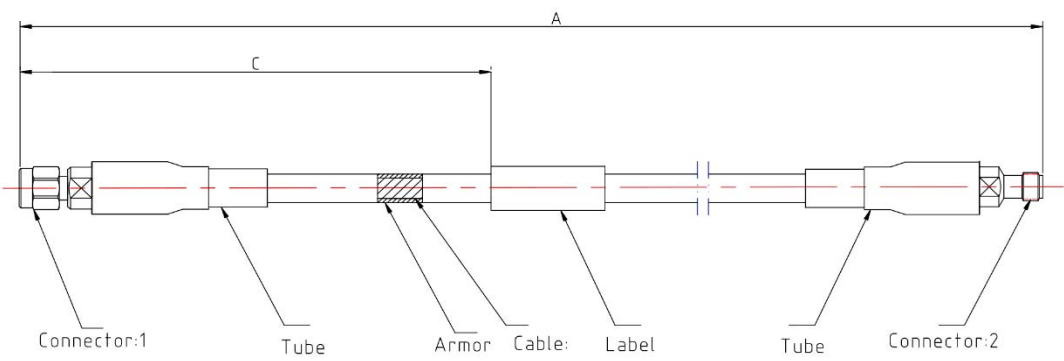
| Model | SMAF-SMA-26L |
|---|---|
|  | |
| All dimensions are in mm; tolerances according to ISO 2768 c | |
| Parts | |
| Connector 1 | SMA Male |
| Connector 2 | SMA Female |
| Cable | RTK 161-YB (or equivalent type) |
| Label | Label Stick |
| Tube | Shrinking tube |
| Armor | Stainless steel interlocked hose with PTFE wire(black+red) jacket |
| Specifications | |
| Frequency | DC ~ 26.5 GHz |
| Impedance | 50 Ω |
| VSWR | ≤1.3 to 26.5 GHz |
| Insertion loss | ≤1.6dB@DC~18GHz, 2.0dB@18~26.5GHz |
| Phase stability vs. Flexure | ≤±8° @26.5 GHz (Wrapped around a 50mm diameter mandrel) |
| Amplitude stability vs. Flexure | ≤±0.2 dB@26.5 GHz (Wrapped around a 50mm diameter mandrel) |
| Minimum bending radius | 38.5 mm |
| Cable Diameter(with armor) | 7.7 mm |
| Temperature range(Operation) | -40℃~+125℃ |
| RoHS | compliant |
| Length A | 1000±10 mm |
| Length C | 200±10 mm |
| Package and storage | |
| The connector is encapsulated with a special dust cap. When the components are bent and packaged, the bending radius should not be less than 5 times the minimum bending radius of the cable. | |
| The storage conditions of the product are: -10℃~+40℃, the relative humidity is not more than 80%, and the surrounding air is free from acidic, alkaline and other corrosive gases. | |

| | |
|--------------|--------------------------|
| Model | V26-N35MN35F-25IN |
|--------------|--------------------------|

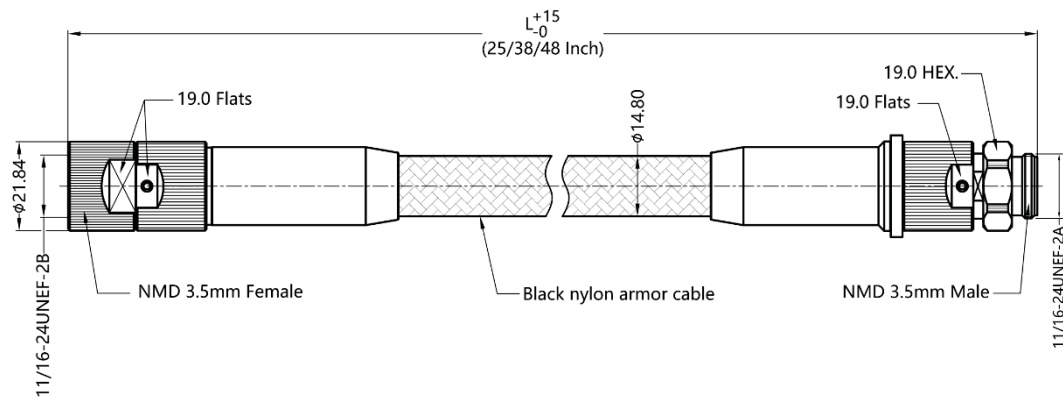

All dimensions are in millimeters tolerances

Parts

| | |
|--------------|---|
| Coupling nut | Stainless steel, passivated |
| Body | Stainless steel, passivated |
| Contact pin | Beryllium copper, gold plated |
| Insulator | PEI & PEEK, natural |
| Cable | Stainless steel double buckle black nylon armor |

Specifications

| | |
|---------------------------------|---------------------|
| Frequency | DC ~ 26.5 GHz |
| Impedance | 50 Ω |
| VSWR | ≤1.25 |
| Insertion loss | ≤2.16 dB |
| Mechanical phase stability | ≤±2.7° |
| Mechanical amplitude stability | ≤±0.08 dB |
| Min. bending radius static | 74 mm |
| Min. bending radius dynamic | 148 mm |
| Recommended coupling torque | 9-14 in-lbs |
| Coupling nut retention force | 100 lbs |
| Durability | 50,000 Cycles(FLEX) |
| Voltage rating | 325 Vrms |
| Dielectric withstanding voltage | 750V(DC) |
| Insulation resistance | 5000 MΩ |
| Temperature range(Operation) | -40°C ~ +85°C |
| RoHS & REACH | compliant |
| Length | 635 mm |

Package and storage

The connector is encapsulated with a special dust cap. When the components are bent and packaged, the bending radius should not be less than 5 times the minimum bending radius of the cable.

The storage conditions of the product are: -10°C ~ +40°C, the relative humidity is not more than 80%, and the surrounding air is free from acidic, alkaline and other corrosive gases.

| | |
|--------------|--------------------------|
| Model | V26-N35FA35F-25IN |
|--------------|--------------------------|

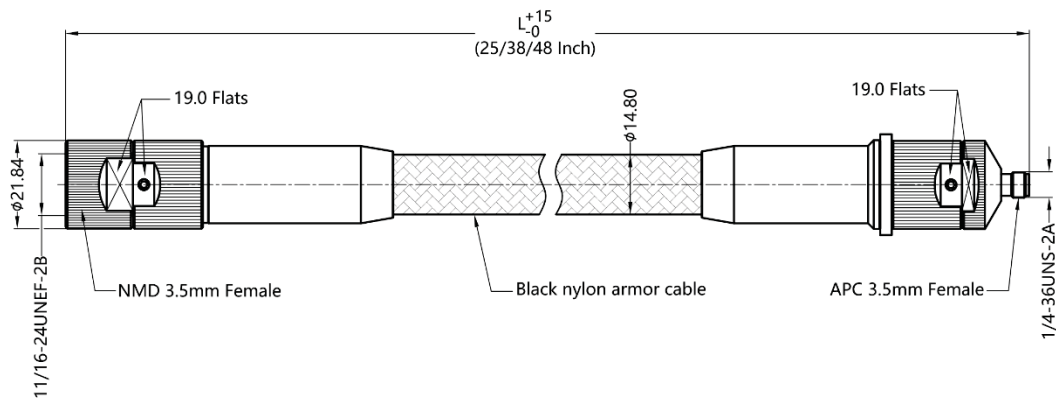

All dimensions are in millimeters tolerances

Parts

| | |
|--------------|---|
| Coupling nut | Stainless steel, passivated |
| Body | Stainless steel, passivated |
| Contact pin | Beryllium copper, gold plated |
| Insulator | PEI & PEEK, natural |
| Cable | Stainless steel double buckle black nylon armor |

Specifications

| | |
|---------------------------------|---------------------|
| Frequency | DC ~ 26.5 GHz |
| Impedance | 50 Ω |
| VSWR | ≤1.25 |
| Insertion loss | ≤2.16 dB |
| Mechanical phase stability | ≤±2.7° |
| Mechanical amplitude stability | ≤±0.08 dB |
| Min. bending radius static | 74 mm |
| Min. bending radius dynamic | 148 mm |
| Recommended coupling torque | 9-14 in-lbs |
| Coupling nut retention force | 100 lbs |
| Durability | 50,000 Cycles(FLEX) |
| Voltage rating | 325 Vrms |
| Dielectric withstanding voltage | 750V(DC) |
| Insulation resistance | 5000 MΩ |
| Temperature range(Operation) | -40°C ~ +85°C |
| RoHS & REACH | compliant |
| Length | 635 mm |

Package and storage

The connector is encapsulated with a special dust cap. When the components are bent and packaged, the bending radius should not be less than 5 times the minimum bending radius of the cable.

The storage conditions of the product are: -10°C ~ +40°C, the relative humidity is not more than 80%, and the surrounding air is free from acidic, alkaline and other corrosive gases.

| | |
|--------------|----------------------|
| Model | S40-29M29F-1M |
|--------------|----------------------|

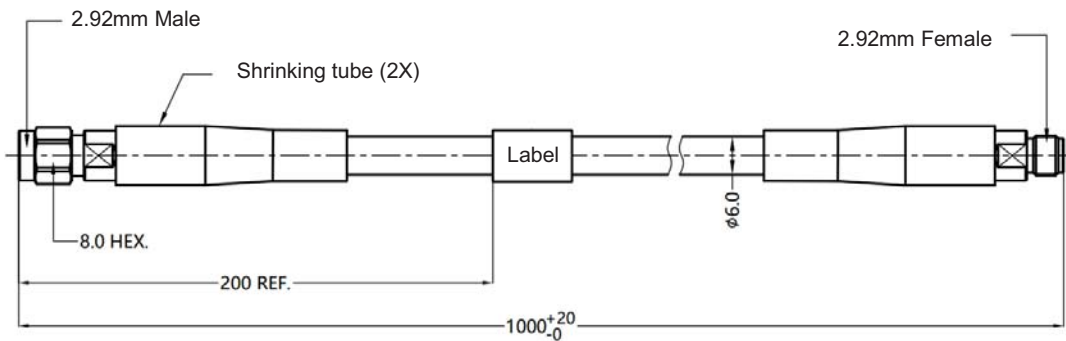

All dimensions are in millimeters tolerances

Parts

| | |
|-------------|---|
| Connector 1 | 2.92mm Male |
| Connector 2 | 2.92mm Female |
| Cable | FSB330PK, Armored low pass phase stable cable (Black+Red) |

Specifications

| | |
|---------------------------------|-------------------|
| Frequency | DC ~ 40 GHz |
| Impedance | 50 Ω |
| VSWR | ≤1.30 @DC~40GHz |
| Insertion loss | ≤3.80dB @DC~40GHz |
| Voltage rating | 335V (rms) |
| Dielectric withstanding voltage | 750V (DC) |
| Insulation resistance | 3000MΩ |
| Mechanical phase stability | ±9° |
| Mechanical amplitude stability | ±0.1dB |
| Minimum bending radius static | 30 mm |
| Minimum bending radius dynamic | 60 mm |
| Recommended coupling torque | 7-9 in-lbs(29M) |
| Coupling nut retention force | ≥60 lbs(29M) |
| Durability | ≥500 cycles |
| Temperature range(Operation) | -40°C ~ +85°C |
| RoHS & REACH | compliant |

Package and storage

The connector is encapsulated with a special dust cap. When the components are bent and packaged, the bending radius should not be less than 5 times the minimum bending radius of the cable.

The storage conditions of the product are: -10°C ~ +40°C, the relative humidity is not more than 80%, and the surrounding air is free from acidic, alkaline and other corrosive gases.

| | |
|--------------|--------------------------|
| Model | V50-N24MN24F-25IN |
|--------------|--------------------------|

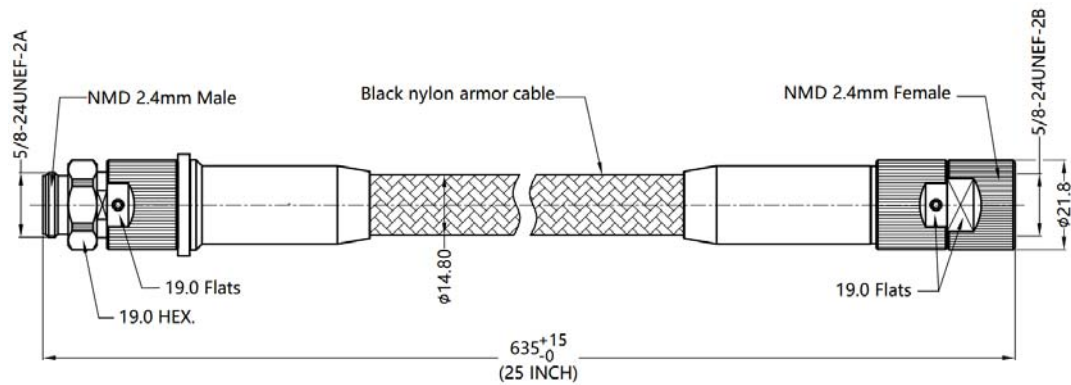

All dimensions are in millimeters tolerances

Parts

| | |
|--------------|---|
| Coupling nut | Stainless steel, passivated |
| Body | Stainless steel, passivated |
| Contact pin | Beryllium copper, gold plated |
| Insulator | PEI & PEEK, natural |
| Cable | Stainless steel double buckle black nylon armor |

Specifications

| | |
|---------------------------------|---------------------|
| Frequency | DC ~ 50 GHz |
| Impedance | 50 Ω |
| VSWR | ≤1.35 |
| Insertion loss | ≤2.98 dB |
| Mechanical phase stability | ≤±3.5° |
| Mechanical amplitude stability | ≤±0.08 dB |
| Min. bending radius static | 74 mm |
| Min. bending radius dynamic | 148 mm |
| Recommended coupling torque | 9-14 in-lbs |
| Coupling nut retention force | 100 lbs |
| Durability | 50,000 Cycles(FLEX) |
| Voltage rating | 325 Vrms |
| Dielectric withstanding voltage | 750V(DC) |
| Insulation resistance | 5000 MΩ |
| Temperature range(Operation) | -40°C ~ +85°C |
| RoHS & REACH | compliant |
| Length | 635 mm |

Package and storage

The connector is encapsulated with a special dust cap. When the components are bent and packaged, the bending radius should not be less than 5 times the minimum bending radius of the cable.

The storage conditions of the product are: -10°C ~ +40°C, the relative humidity is not more than 80%, and the surrounding air is free from acidic, alkaline and other corrosive gases.

| | |
|--------------|--------------------------|
| Model | V50-N24FA24F-25IN |
|--------------|--------------------------|

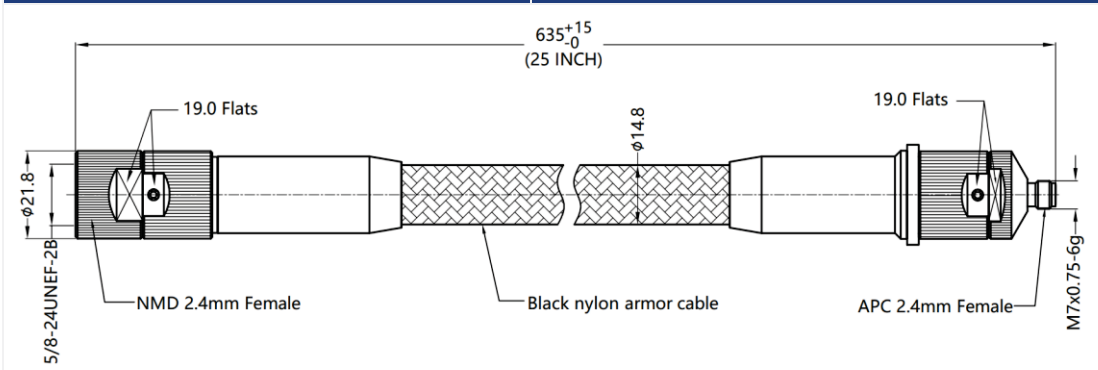

All dimensions are in millimeters tolerances

| Parts | |
|-------|--|
|-------|--|

| | |
|--------------|---|
| Coupling nut | Stainless steel, passivated |
| Body | Stainless steel, passivated |
| Contact pin | Beryllium copper, gold plated |
| Insulator | PEI & PEEK, natural |
| Cable | Stainless steel double buckle black nylon armor |

| Specifications | |
|----------------|--|
|----------------|--|

| | |
|---------------------------------|---------------|
| Frequency | DC ~ 50 GHz |
| Impedance | 50 Ω |
| VSWR | ≤1.35 |
| Insertion loss | ≤2.98 dB |
| Mechanical phase stability | ≤±3.5° |
| Mechanical amplitude stability | ≤±0.08 dB |
| Min. bending radius static | 74 mm |
| Min. bending radius dynamic | 148 mm |
| Recommended coupling torque | 9-14 in-lbs |
| Coupling nut retention force | 100 lbs |
| Durability | 10,000 Cycles |
| Voltage rating | 325 Vrms |
| Dielectric withstanding voltage | 750V(DC) |
| Insulation resistance | 5000 MΩ |
| Temperature range(Operation) | -40°C ~ +85°C |
| RoHS & REACH | compliant |
| Length | 635 mm |

| Package and storage | |
|---------------------|--|
|---------------------|--|

The connector is encapsulated with a special dust cap. When the components are bent and packaged, the bending radius should not be less than 5 times the minimum bending radius of the cable.

The storage conditions of the product are: -10°C ~ +40°C, the relative humidity is not more than 80%, and the surrounding air is free from acidic, alkaline and other corrosive gases.

| | |
|--------------|------------------------|
| Model | 2.92F-2.92F-40A |
|--------------|------------------------|

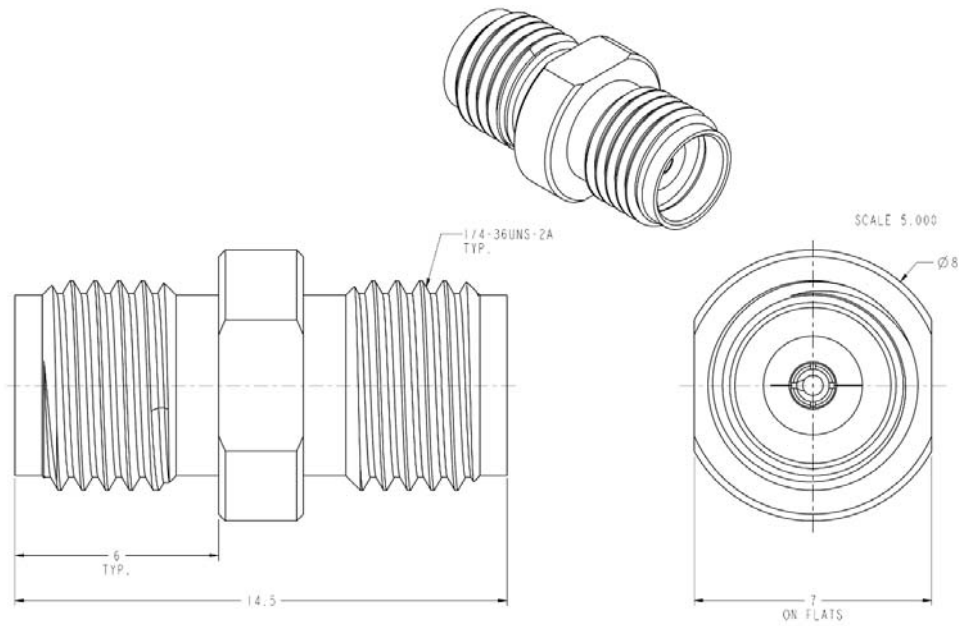

All dimensions are in millimeters tolerances

| Parts | |
|-------|--|
|-------|--|

| | |
|-----------|-------------------------------|
| Connector | 2.92mm Female - 2.92mm Female |
| Body | Stainless sheet, passivated |
| Contact | Beryllium copper, gold plated |
| Insulator | PEI, NATURAL |

| Specifications | |
|----------------|--|
|----------------|--|

| | |
|------------------------------|----------------|
| Frequency | DC ~ 40 GHz |
| Impedance | 50 Ω |
| VSWR | 1.25 Max. |
| Insertion loss | 0.3 dB Max. |
| Dielectric withstand voltage | 1000 VRMS Min. |
| Temperature range(Operation) | -40℃ ~ +85℃ |
| Durability | 2000 cycles |

| Package and storage | |
|---------------------|--|
|---------------------|--|

The connector is encapsulated with a special dust cap. The storage conditions of the product are: -10℃ ~ +40℃, the relative humidity is not more than 80%, and the surrounding air is free from acidic, alkaline and other corrosive gases.

| | |
|--------------|------------------------|
| Model | 1.85F-2.92F-40A |
|--------------|------------------------|

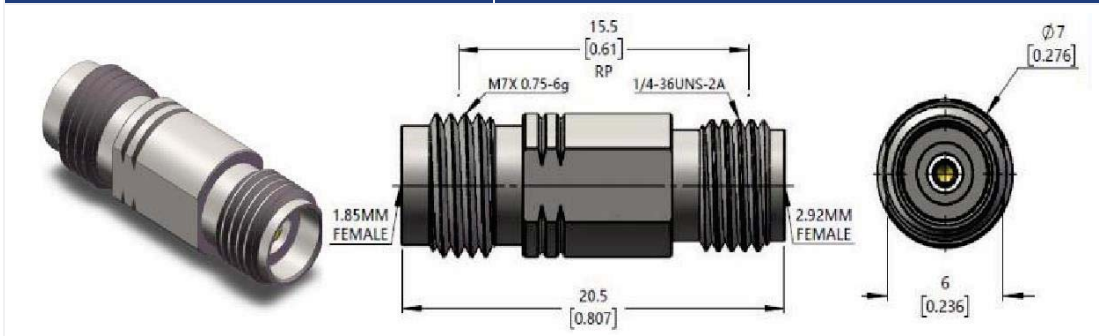

All dimensions are in millimeters tolerances

| Parts | |
|-------|--|
|-------|--|

| | |
|-----------|-------------------------------|
| Connector | 1.85mm Female - 2.92mm Female |
| Body | Stainless sheet, passivated |
| Contact | Beryllium copper, gold plated |
| Insulator | PEI |

| Specifications | |
|----------------|--|
|----------------|--|

| | |
|------------------------------|-----------------------|
| Frequency | DC ~ 40 GHz |
| Impedance | 50 Ω |
| VSWR | 1.15 Typ ; 1.20 Max |
| Insertion loss | 0.05* $\sqrt{f_GHz}$ |
| Insulation Resistance | 5000 MΩ |
| Temperature range(Operation) | -55°C ~ +165°C |

| Package and storage | |
|---------------------|--|
|---------------------|--|

The connector is encapsulated with a special dust cap. The storage conditions of the product are: -10°C ~ +40°C, the relative humidity is not more than 80%, and the surrounding air is free from acidic, alkaline and other corrosive gases.

| | |
|--------------|------------------------|
| Model | 1.85F-1.85F-67A |
|--------------|------------------------|

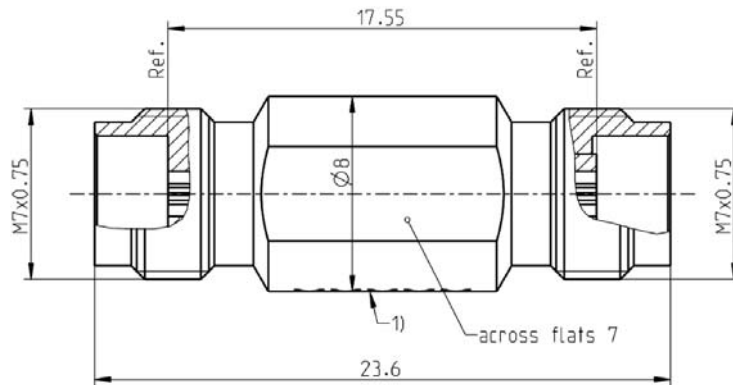

All dimensions are in mm; tolerances according to ISO 2768 m-H

| Parts | |
|-------|--|
|-------|--|

| | |
|-----------|-------------------------------|
| Connector | 1.85mm Female – 1.85mm Female |
| Body | Stainless sheet, passivated |
| Contact | CuBe, gold plated |
| Insulator | PEEK |

| Specifications | |
|----------------|--|
|----------------|--|

| | |
|----------------------------|--------------------------------|
| Frequency | DC ~ 67 GHz |
| Impedance | 50 Ω |
| Return loss | ≥ 17 dB @ DC to 67 GHz |
| Insertion loss | ≤ 0.05* $\sqrt{f_GHz}$ |
| Insulation resistance | ≥ 5 GΩ |
| Center contact resistance | ≤ 4 mΩ |
| Outer contact resistance | ≤ 2.5 mΩ |
| Test voltage | 500 V rms |
| Working voltage | 150 V rms |
| RF-leakage | ≥ 100 dB up to 1.0 GHz |
| Mating cycles RPC-1.85 | ≥ 500 |
| Center contact captivation | axial: ≥ 20 N, Radial: ≥ 1 Ncm |
| Coupling test torque | ≤ 1.65 Nm |
| Recommended torque | 0.8 Nm to 1.1 Nm |
| Temperature range | -55°C ~ +165°C |
| RoHS | compliant |

| Package and storage | |
|---------------------|--|
|---------------------|--|

The connector is encapsulated with a special dust cap. The storage conditions of the product are: -10°C ~ +40°C, the relative humidity is not more than 80%, and the surrounding air is free from acidic, alkaline and other corrosive gases.

| Model | UKitSSA3X | |
|--|--|--|
|  | | |
| Parts | | |
| N(M)-SMA(M) Cable | DC ~ 6 GHz, VSWR<1.25, 700 mm | |
| N(M)-N(M) Cable | DC ~ 6 GHz, VSWR<1.25, 700 mm | |
| 2* N(M)-BNC(F) Adaptor | DC ~ 2 GHz, VSWR<1.2 | |
| 2* N(M)-SMA(F) Adaptor | DC ~ 6 GHz, VSWR<1.2 | |
| 10 dB attenuator N-N | DC ~ 6 GHz, VSWR<1.2, Power:1 W, 50 mm×16 mm | |
| Package and storage | | |
| <p>The connector is encapsulated with a special dust cap. The storage conditions of the product are: -10°C ~ +40°C, the relative humidity is not more than 80%, and the surrounding air is free from acidic, alkaline and other corrosive gases.</p> | | |



About SIGLENT

SIGLENT is an international high-tech company, concentrating on R&D, sales, production and services of electronic test & measurement instruments.

SIGLENT first began developing digital oscilloscopes independently in 2002. After more than a decade of continuous development, SIGLENT has extended its product line to include digital oscilloscopes, isolated handheld oscilloscopes, function/arbitrary waveform generators, RF/MW signal generators, spectrum analyzers, vector network analyzers, digital multimeters, DC power supplies, electronic loads and other general purpose test instrumentation. Since its first oscilloscope was launched in 2005, SIGLENT has become the fastest growing manufacturer of digital oscilloscopes. We firmly believe that today SIGLENT is the best value in electronic test & measurement.

Headquarters:

SIGLENT Technologies Co., Ltd
Add: Bldg No.4 & No.5, Antongda Industrial Zone,
3rd Liuxian Road, Bao'an District,
Shenzhen, 518101, China
Tel: + 86 755 3688 7876
Fax: + 86 755 3359 1582
Email: sales@siglent.com
Website: int.siglent.com

North America:

SIGLENT Technologies NA, Inc
Add: 6557 Cochran Rd Solon, Ohio 44139
Tel: 440-398-5800
Toll Free: 877-515-5551
Fax: 440-399-1211
Email: support@siglentna.com
Website: www.siglentna.com

Europe:

SIGLENT Technologies Germany GmbH
Add: Staetzlinger Str. 70
86165 Augsburg, Germany
Tel: +49(0)-821-666 0 111 0
Fax: +49(0)-821-666 0 111 22
Email: info-eu@siglent.com
Website: www.siglenteu.com

Malaysia:

SIGLENT Technologies (M) Sdn.Bhd
Add: NO.6 Lorong Jelawat 4
Kawasan Perusahaan Seberang Jaya
13700, Perai Pulau Pinang
Tel: 006-04-3998964
Email: sales@siglent.com
Website: int.siglent.com

CALTRON PTE LTD
email: caltron@caltron.sg
www.caltron.sg

Follow us on
Facebook: [SiglentTech](https://www.facebook.com/SiglentTech)

