



High Performance Dielectric, Conductivity and Electrochemical Impedance Analyzers

- Concepts
- Features
- Principles of Operation
- Application Examples

Introduction

Novocontrol spectrometers for dielectric, conductivity and impedance material analysis have a world-wide reputation for highest quality and flexibility. Several systems for frequencies from μHz up to GHz are available. Sample cells are offered in standard parallel plate transmission and reflection geometry, four wire contact arrangement and as interdigit comb electrodes. This allows characterization of solid materials, liquids, powders and thin films. Several temperature control systems covering a range from -160°C – 1600°C are available. Within a modular concept, several impedance analysis systems can be combined with each temperature control

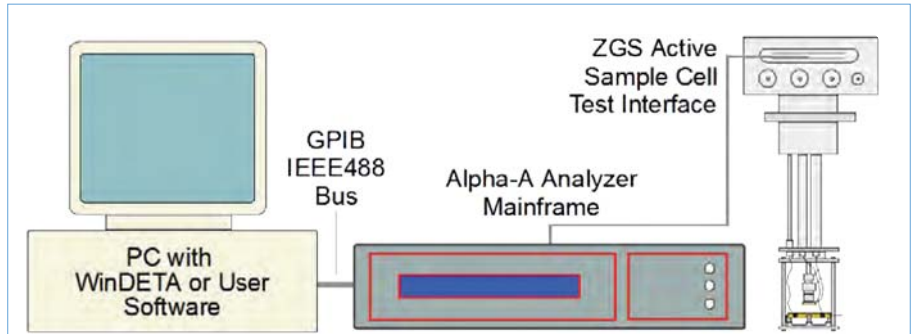

Fig.1: The Active Sample Cell Test Interface (ZGS) converts the sample current and voltage into two voltage signals, providing access to the sample impedance which is converted to complex permittivity or conductivity. All system functions are controlled by the Alpha-A mainframe via high level GPIB commands and thus can easily be integrated in self-written programs. Optional turn key operation, including data evaluation, visualization and data export, is provided by Novocontrol DE-TACHEM/WinFIT software.

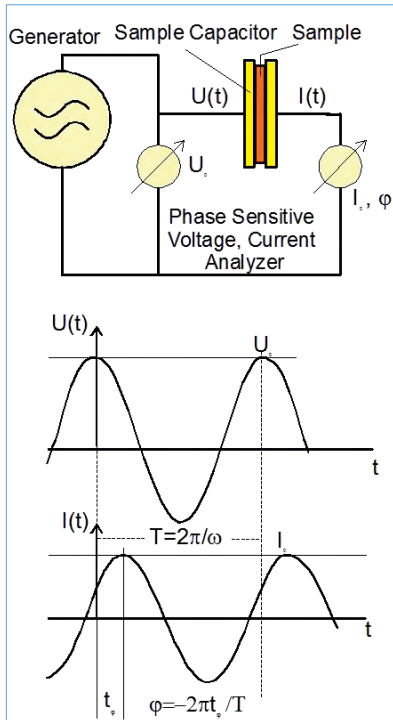

Fig. 2: Principles of impedance and material measurement

$$U(t) = U_0 \cos(\omega t)$$

$$I(t) = I_0 \cos(\omega t + \varphi) = \text{re}(I^* \exp(j\omega t))$$

Fourier Transform over n Periods

$$I^*(\omega) = I' + iI'' = \frac{2}{nT} \int_0^{nT} I(t) \exp(i\omega t) dt$$

$$I_0 = \sqrt{I'^2 + I''^2}; \tan(\varphi) = \frac{I''}{I'}$$

$$\text{Impedance } Z^*(\omega) = Z' + iZ'' = \frac{U_0}{I^*(\omega)}$$

Permittivity

$$\varepsilon^*(\omega) = \varepsilon' - i\varepsilon'' = \frac{-i}{\omega Z^*(\omega) C_0}$$

C_0 , Empty Cell Capacity

Conductivity

$$\sigma^*(\omega) = \sigma' - i\sigma'' = \frac{1}{Z^*(\omega) A} d$$

d Electrode Spacing; A Electrode Area

system and most of the sample cells. Automatic system and experiment control and sophisticated data evaluation is performed by WinDETA and WinFIT software packages which have established a world-wide standard in dielectric, conductivity and impedance material analysis.

New approach to material analysis

In the frequency range from $3 \mu\text{Hz}$ to 40 MHz, the Novocontrol Alpha and Beta analyzer series are used as the base spectrometer component which measures complex impedance of a sample material prepared between two or more electrodes. The instruments can be used as general purpose precision impedance analyzers as well, but are especially designed for dielectric, conductivity, and electro-

chemical impedance material spectroscopy.

Alpha and Beta series

The single-unit Alpha and Beta analyzers combine a series of exceptional features like ultra wide impedance range, frequency range and high accuracy in a fully automated and easy to use instrument. These systems represent a milestone in economical high performance instrumentation. The Beta analyzer has the same functionality as the Alpha analyzer, but has additional high impedance differential voltage inputs for three- or four-electrode measurements as indicated in Figure 3 and Table 1.

Alpha-A modular series

The exceptional performance of the Alpha and Beta analyzers is extended by the more recent Alpha-A modular series with additional functionality like, e.g., extended voltage and current ranges, fast measurement rates and dc measurement functionality, including potentiostat and galvanostat control functions. As these features are, for both technical and economical

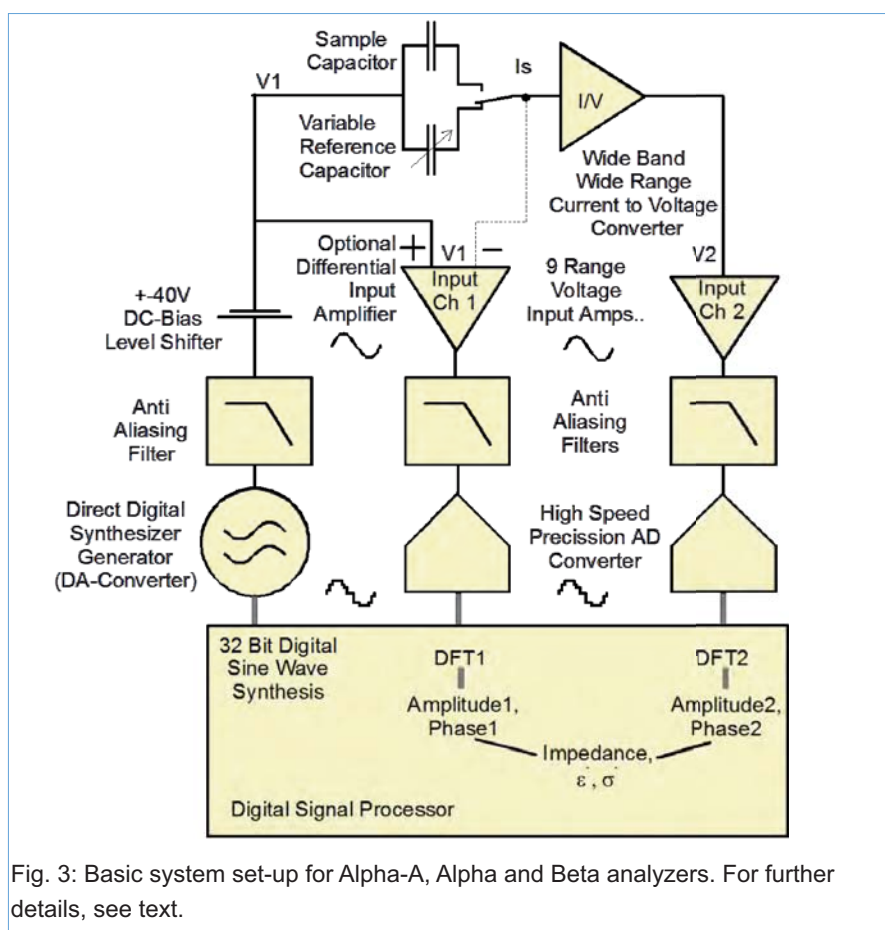

Fig. 3: Basic system set-up for Alpha-A, Alpha and Beta analyzers. For further details, see text.

reasons, difficult to implement in a single instrument, the Alpha-A system consists of an Alpha-A mainframe unit

which can be connected to a series of test interfaces (one at a time), controlled by the mainframe. At least one test interface is required in order to perform an impedance measurement.

Alpha-A versus Alpha and Beta series

The Alpha-A is the successor of the Alpha and Beta analyzers which are still available as economical alternatives. The Alpha-A system not only provides all functions already present in the Alpha and Beta series analyzers, but additionally supports a large selection of test interfaces. As a consequence, the Alpha-A series is our most powerful and flexible system and thus the recommended solution for all new instrument designs. Basic features of all three analyzer series are listed in Table 1.

In the following, we will concentrate on the common features and technical principles of the Alpha-A, Alpha and Beta series only. The par-

Function	Alpha-A	Alpha	Beta
Dielectric Spectroscopy Conductivity Spectroscopy Impedance Spectroscopy	with additional test interfaces	x	x
Gain-Phase Measurements	x		x
Test Interface Support	x		
Three- and four-electrode configurations	with ZG4 and POT/GAL test interfaces		x
Non-linear Spectroscopy	x	x	x
Active Sample Cell specified at the electrodes	with ZGS test interface		
High voltage	with HVB 300, HVB 1000, HVB 4000		
High current	with POT/GAL 30 V-2A and POT/GAL 15 V-10A		
Potentiostat function Galvanostat function	with POT/GAL 30 V-2A and POT/GAL 15 V-10 A		
Fast measurements up to 150 points/s	with mainframe option F		
dc bias option	with option B	with option B	with option B

Tab. 1: Functions of the Alpha-A, Alpha and Beta analyzer series.

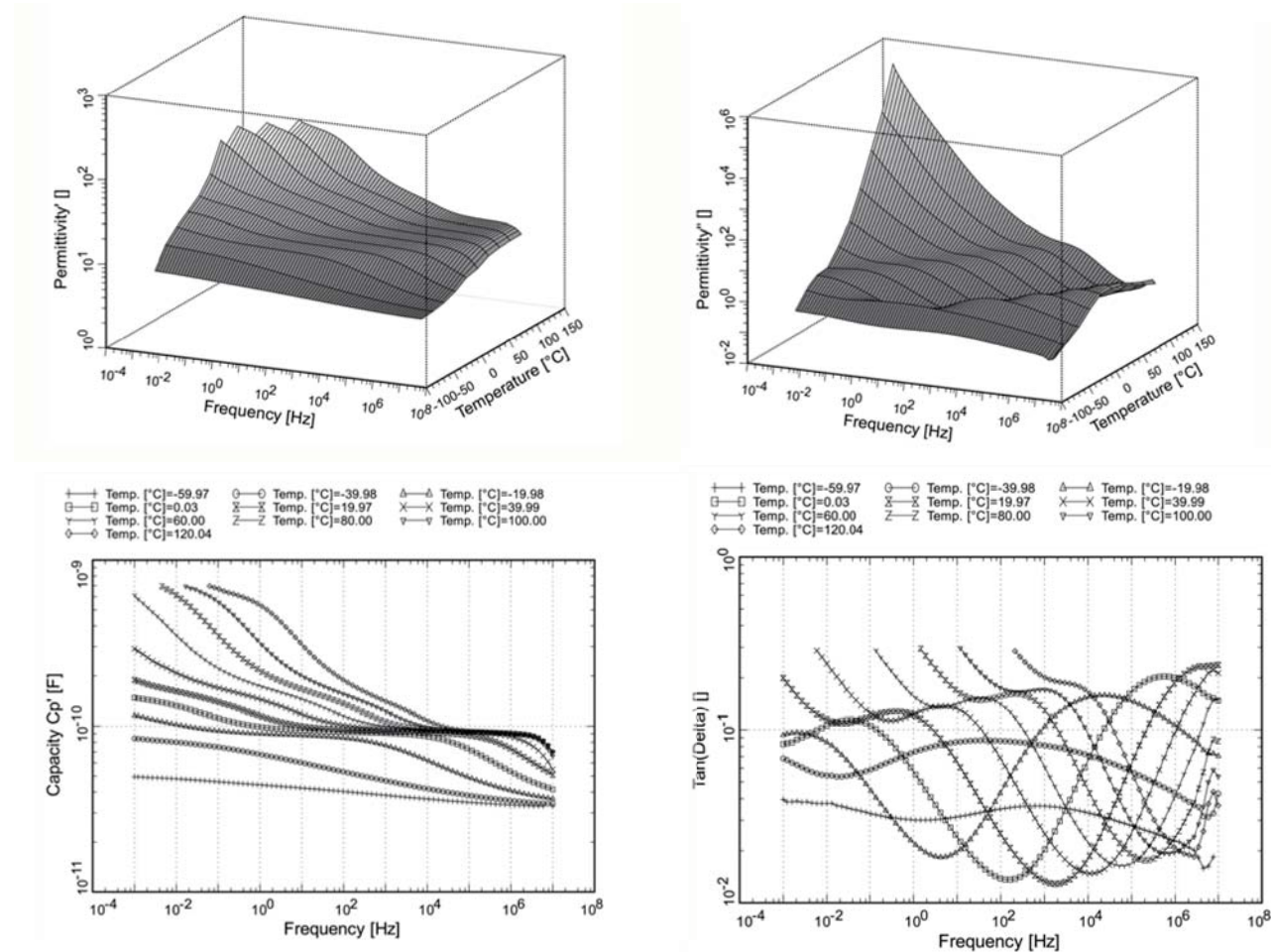

Fig. 4: PVDF results, 3D representation of permittivity, 2D diagrams for measured capacity and loss factor $\tan \delta$.

ticular functions of the Alpha-A test interfaces and the modular concept are described in the Novocontrol technical brochure "Test Interfaces for the Alpha-A Modular Measurement System".

Characterization of low loss dielectrics

Due to the extraordinary high upper impedance limit beyond $10^{14} \Omega$, nearly all kinds of dielectrics and isolators can be characterized even down to very low frequencies, i.e., below the mHz range. The high accuracy in loss factor $\tan \delta < 3 \cdot 10^{-5}$ (resolution $< 10^{-5}$) provides access to material properties previously not accessible. Even lowest-loss materials used in ceramic capacitors, isolators in power industry or weakest molecular relaxations can be analyzed over an extremely wide fre-

quency range.

No limitations: High and low conductive materials

In contrast to other systems for dielectric spectroscopy, the Alpha-A, Alpha and Beta analyzers are by no means limited to high-impedance dielectric samples. On the contrary: the lower impedance limit of 0.01Ω (0.0001Ω for four-wire configurations) allows also to analyze conductive samples like semiconductors, electrolytes and electrochemical systems equally well. As the complete impedance range of 16 orders of magnitude is accessible, even samples exhibiting drastic changes of impedance with temperature or other external settings (e.g., temperature-induced metal-insulator-transitions) can be fully characterized in one single device

configuration.

Capacities down to 1 fF

The combination of ultra-wide impedance range and broadband high accuracy results in an exceptionally broad capacity range as well. With most impedance or dielectric analyzers, small capacities in the pF range or even below are usually hardly accessible if at all.

The Alpha-A, Alpha or Beta analyzers, however, are specified to measure capacities as low as 1 fF (0.001 pF) within 10 Hz – 500 kHz. Applications are, e.g., broadband characterizations of small crystals, measurements of stray capacities or impedance of ill-defined electrode geometries like, e.g., two needle electrodes separated by 1 cm sample material.

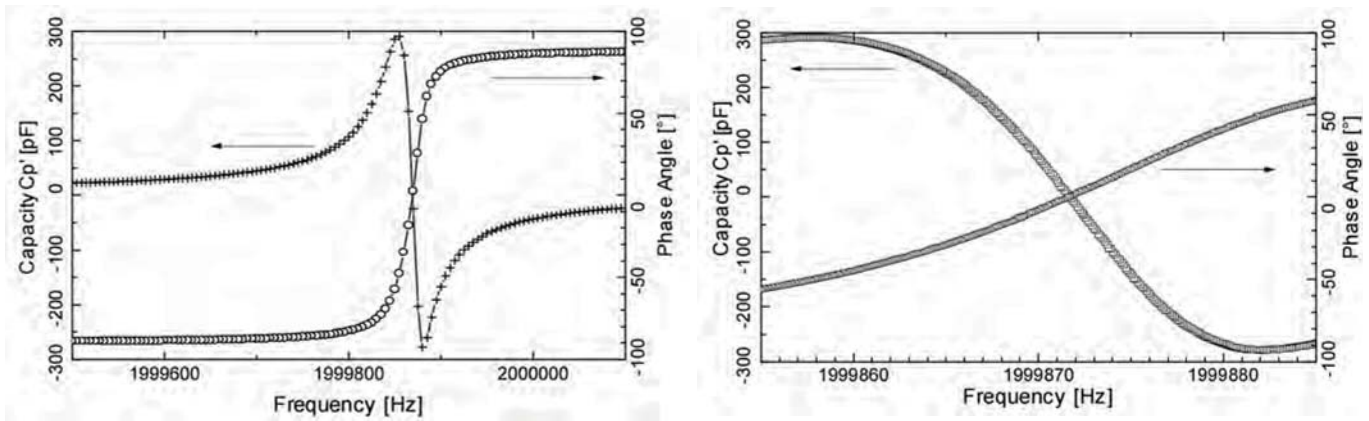

Fig. 5: Dielectric properties of a 2 MHz quartz crystal, half power bandwidth: 30 Hz; 5 Hz and 0.1 Hz frequency resolution for the left and right diagram, respectively.

Specified at the sample position

In the Alpha-A in combination with a ZGS active sample cell test interface, the impedance converter is directly mounted on top of the sample cell connected by rigid lines. This set-up guarantees high accuracy up to 40 MHz and provides optional control of sample temperature. The accuracy specification for material measurements applies to the sample position, offering a highly accurate turnkey solution without calibration errors due to cable inductance, contacts, stray capacities, grounding and shielding.

Innovative technology

The Alpha-A, Alpha and Beta analyzers are based on state of the art digital signal processing techniques. Automatic device control including self calibration is provided by the Novocontrol Windows software WinDETA.

As shown in fig. 2, the basic operation is to create a sine wave at the frequency of interest, apply it to the sample and measure the sample voltage $U(t)$ and result current $I(t)$. From this, the amplitude I_0 and phase angle φ of the current harmonic base wave component $I^*(\omega)$ is calculated by complex Fourier transform (FT) of $I(t)$. In addition to the phase detection, the FT suppresses all frequency components in $I(t)$ except a narrow band centred around the generator frequency. This improves accuracy and reduces noise and DC drifts by sever-

al orders of magnitude. E.g. measuring a signal covered by a noise signal of 1000 times larger is possible. Finally, the impedance $Z(\omega)$ and material parameters $\epsilon^*(\omega)$ and $\sigma^*(\omega)$ are calculated.

Digital signal synthesis

Such kind of set-up is implemented in the Alpha series as shown in Figure. 3. The optional high impedance differential input amplifier is only included in the Beta series. For the Alpha-A series, Fig. 3 has to be separated in two parts. The lower part includes the frequency response analyzer portion from the two input channels down to the signal processor. The upper part with the impedance converter, reference capacitors, differential input amplifier and additional not shown components are realized within several test interfaces. For details, cf. Table 1 and the Novocontrol technical brochure "*Test Interfaces for Alpha-A Modular Measurement System*".

As shown in Fig. 3, a digital signal processing system is used for both frequency generation and analysis of the input signals. The generator signal is directly digitally synthesized over the entire frequency range. At a rate of 400 MHz, the signal processor continuously calculates digital sine wave values which are transformed into a sine wave voltage. This is done by a high speed digital analog converter (DAC) followed by a higher harmonic filter. This kind of signal generation

guarantees highest stability and a frequency resolution of 32 bit corresponding to, e.g., 10 mHz out of 40 MHz.

Digital signal analysis

The voltages from two independent input channels are amplified, filtered and converted into two digital data streams; these are analyzed online with respect to their harmonic base waves by discrete Fourier transform (DFT) in a phase-sensitive manner.

Channel 1 measures the voltage applied to the sample (V_1). The resulting sample current I_s is transformed by the precision impedance converter into the voltage V_2 measured by channel 2.

Reference technique

Major parts of the signal generation and analysis are performed in the digital system area. Phase and stability errors are minimized to negligible values. In order to reach similar high accuracy in the analog system components as well, all Novocontrol Technologies analyzers apply a particular reference technique: after each measured impedance point, the sample is disconnected, and a precision low-loss reference capacitor is measured under the same conditions. The results of the reference measurement are used to eliminate all linear systematic deviations. This technology, in combination with a straightforward digital design, provides the high

accuracy required for material analysis and, in particular, spectroscopy of low-loss dielectrics.

Measurement examples

The performance for low-loss materials is shown and discussed in the following article. The measurements in Figs. 4 and 5 were performed using an Alpha-A analyzer with active sample cell test interface ZGS and a Quatro Cryosystem for temperature control. In order to demonstrate the overall system performance, PVDF [1] was chosen as a material with moderate loss. Figure 4 shows the dielectric spectrum for frequencies from 1 mHz to 10 MHz at several temperatures. PVDF shows α and β relaxations with losses ($\tan \delta$) in the range from 0.01 to 0.2. At higher temperatures, the dc conductivity creates a low frequency increase of ϵ'' . As shown in the three-dimensional diagrams, the data can be measured over the entire frequency and temperature range nearly without artefacts. In order to show the results in more detail, the diagrams for capacity C_p' and $\tan \delta$ were confined to the range of interest.

As a demonstration of the frequency resolution and stability, a commercial high Q quartz crystal. The samples was mounted in the ZGS active sample cell; measurements were performed at a stabilized temperature of $20.00 \text{ }^\circ\text{C} \pm 0.01 \text{ }^\circ\text{C}$. Figure 5 shows the dielectric properties with the typical resonant behaviour. The resonance frequency f_0 is at 1999871.8 Hz with a half power width of 30 Hz. Below f_0 , the device behaves like a 22 pF capacitor with -90° phase shift. With increasing frequency, the real part of capacity, C_p' , and the phase shift increases as well. At f_0 , the impedance becomes purely resistive, indicated by vanishing C_p' and phase shift. Above f_0 , the impedance changes to inductive behaviour corresponding to 90° phase shift and a corresponding negative C_p' . As shown in Fig. 5, even at 0.1 Hz resolution the measurements are free of any artefacts and noise. It

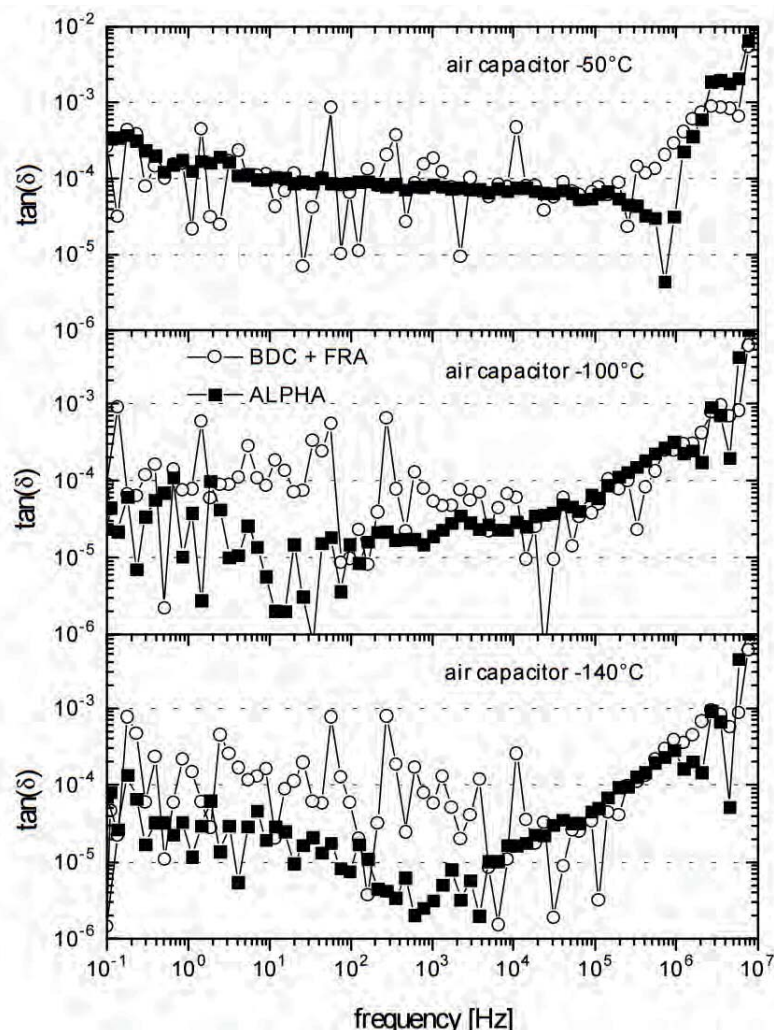

Fig. 1: $\tan \delta$ of an air capacitor (thickness: 50 μm , diameter: 30 mm) at different temperatures measured Alpha Dielectric Analyzer (solid squares) and the combination Broadband Dielectric Converter BDC + frequency response analyzer (open circles)

should be emphasized that each data point is independently measured without averaging or correlation to neighbouring points. Moreover, there is no synchronization between the sample crystal and the Alpha internal oscillator.

References

PVDF samples were supplied by Elf Atochem France, Materials Research Lab., Dr. B. Ernst, 27470 Serquigny, France

Dr. Gerhard Schaumburg

Dr. Dirk Wilmer

Novocontrol Technologies GmbH & Co. KG

Broadband Dielectric Measurement Techniques – Recent Progress

High resolution measurements in the frequency range from 10^{-4} Hz to 10^7 Hz are based on frequency response analysis. This contribution provides the measurement results of a performance comparison of the Novocontrol Alpha High Resolution Dielectric / Impedance Analyzer with a combination of a Broadband Dielectric Converter and a frequency response analyzer (BDC + FRA).

As a low loss test sample, an air capacitor mounted in the sample cell of each system was used. It was prepared from parallel gold plated elec-

trodes with 30 mm diameter. The electrode distance was adjusted to 50 μm by two silica spacer rods resulting in about 125 pF capacity.

Due to the conductance of the rods, the capacitor shows especially at ambient temperature remaining losses. By cooling the capacitor to low temperatures, the conductivity of the spacer rods decreases and the losses are continuously reduced.

This kind of capacitor is well suited for testing the $\tan \delta$ accuracy and resolution of dielectric analysis systems. Results for three different temperatures are shown in Figure 1. At $-50\text{ }^\circ\text{C}$ and frequencies above 10 Hz, the capacitor losses are approx. $\tan \delta \gg 10^{-4}$. At lower frequencies, $\tan \delta$ increases to about $3 \cdot 10^{-4}$ at 0.1 Hz. This dependence can be measured without significant noise by the Alpha analyzer at frequencies below 100 kHz. The combination BDC + FRA shows the same dependency, but superimposed by about 100 % noise due to the system resolution limit $\tan \delta$ of 10^{-4} which is of the same order as the sample loss.

If the temperature is lowered to $-100\text{ }^\circ\text{C}$ and $-140\text{ }^\circ\text{C}$, the capacitor losses decrease further and the better resolution limit of the Alpha analyzer is the limiting factor as shown in the lower two diagrams of Figure 1. Compared to the BDC + FRA combination, the resolution is improved from 10^{-4} to 10^{-5} . At the high frequency end above 100 kHz, the results show an increase in $\tan \delta$ which is not intrinsic to the sample, but due to high frequency limitations for both systems. At 10 MHz, the accuracy is decreased to about $\tan \delta \gg 0.01$ corresponding to about 1° phase accuracy.

Figure 2 shows similar measurements for a low loss polyethylene sample at ambient temperature. The sample capacity is about 160 pF and in good agreement for both systems. The difference of about 1 % in the absolute value is due to stray capacities and mounting deviations of the differ-

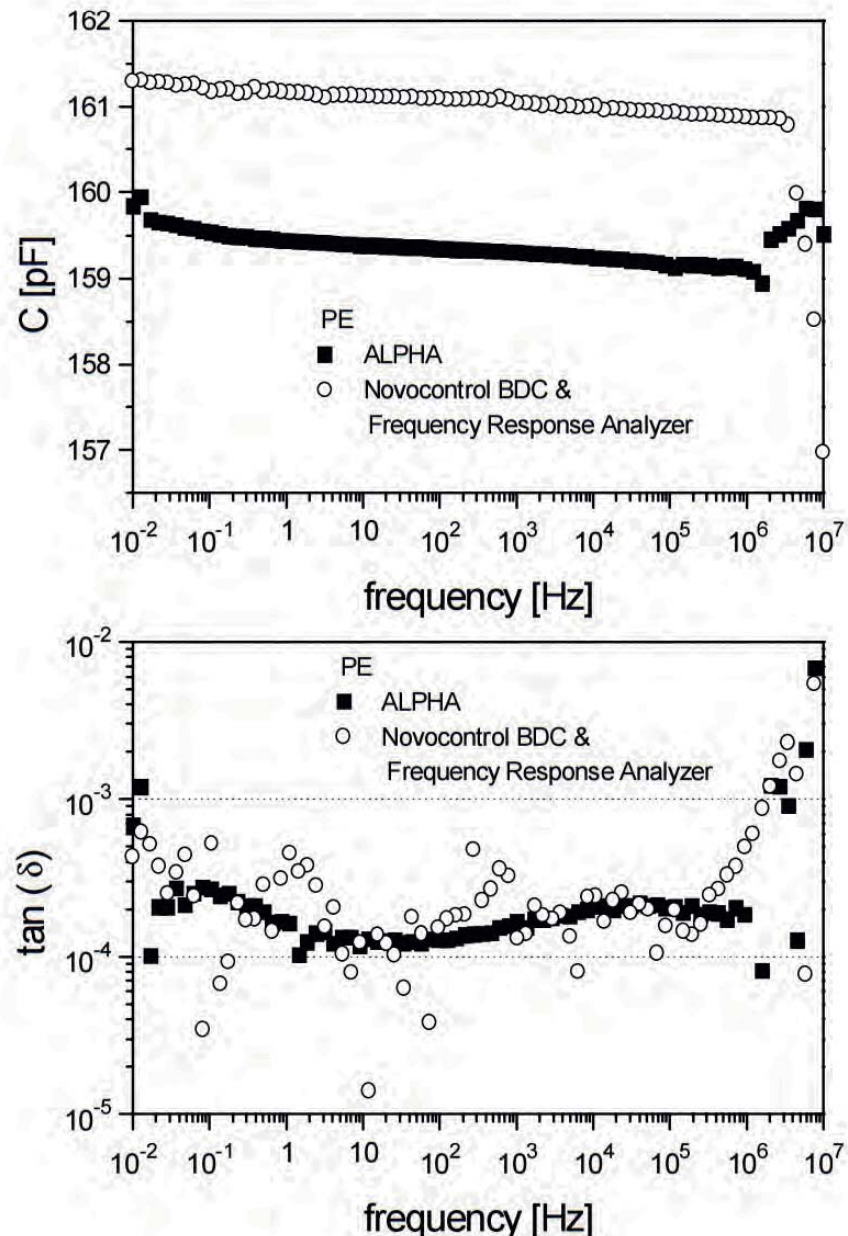

Fig. 2: Capacitance C_p' and $\tan \delta$ of a Polyethylene (PE) sample (thickness: 40 μm , diameter: 20 mm) otherwise as Fig. 1.

ent sample cells. The $\tan \delta$ of the sample is between 10^{-4} and $3 \cdot 10^{-4}$. The results of the two measurement systems show the same behaviour as for the low loss capacitor. Whereas for the BDC + FRA combination the phase resolution limit is reached, the results can be resolved with only 10 % scatter by the Alpha. The $\tan \delta$ increase at high frequencies is again due to internal limitations of both systems. This limitation can be seen in the capacity too. The deviations at 10 MHz are about 1.5 pF for the Alpha

and about 8 pF for the BDC + FRA combination.

Prof. Dr. Friedrich Kremer,
Universität Leipzig, Linnéstr.5,
04103 Leipzig, Germany

novoccontrol

Novocontrol Technologies
GmbH & Co. KG
Aubachstr. 1
56410 Montabaur
Germany
Phone: +49 2602 9196690
Fax: +49 2602 91966933
e-mail: novo@novoccontrol.de
web: <http://www.novoccontrol.de>