

High-End Amplifier Test

FX100 USE CASE



Verifying a high-end amplifier is a typical challenge that requires not only a wide range of measurement functions, but also top-notch specifications of the audio analyzer.

The FX100 suits this application and was therefore chosen by a leading manufacturer of linear power amplifiers as the preferred solution.

Highlights

- Fully integrated solution for lab and production testing.
- Covers not only standard, but also custom-specific measurements.
- Top-notch specifications of the analyzer ensure accurate test results.

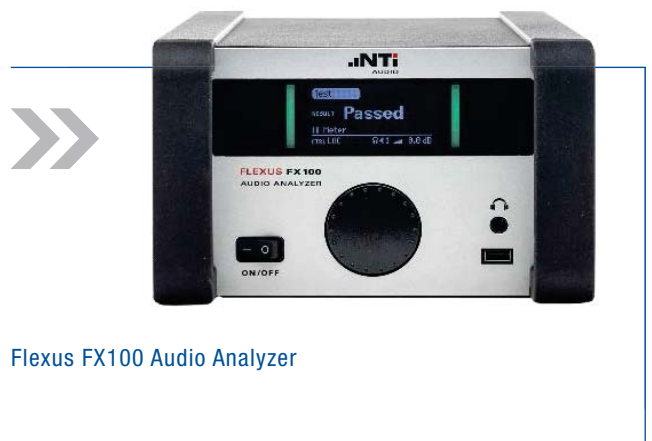

Flexus FX100 Audio Analyzer

THE CHALLENGE

Power audio amplifiers are sophisticated devices that are used in a variety of applications. A full performance check of such a device consequently requires a test solution that offers a wide range of measurement functions, top-notch specifications and a thought-out safety concept.

The standard tests include noise, hum, distortion, linearity, frequency response and output power, which are typically acquired on a dedicated test stand that also includes a power shunt resistor.

THE SOLUTION

Thanks to the versatility, outstanding specifications and speed of the FX100 Audio test system, an acknowledged European manufacturer of professional power amplifiers selected the instrument for their lab as well as production testing.

An important criterion during the evaluation process was the ability of the system to cope with the complexity of the test. The FX-Control software established an efficient test procedure that executes the specified measurements in three different acquisition modes.

GlideSweep

- Level, gain, phase, distortion
- Output power*

StepSweep

- Crosstalk L / R
- Linearity, Maximum output level* @ <1% THD

FFT

- Noise, hum

SYSTEM OVERVIEW

Hardware

- NTi Audio FX100 2-chn Audio analyzer
- Low-induction load resistors

Control software

- FX-Control

* Calculated by FX-Control

Measurements

Step 1 (GlideSweep)

- Frequency response
- Phase
- Total Harmonic Distortion (THD)
- Gain
- Output power

Step 2 (StepSweep)

- Crosstalk left / right
- Linearity (amplitude sweep)
- Maximum output level @ <1 % THD

Step 3 (FFT)

- Noise
- Hum

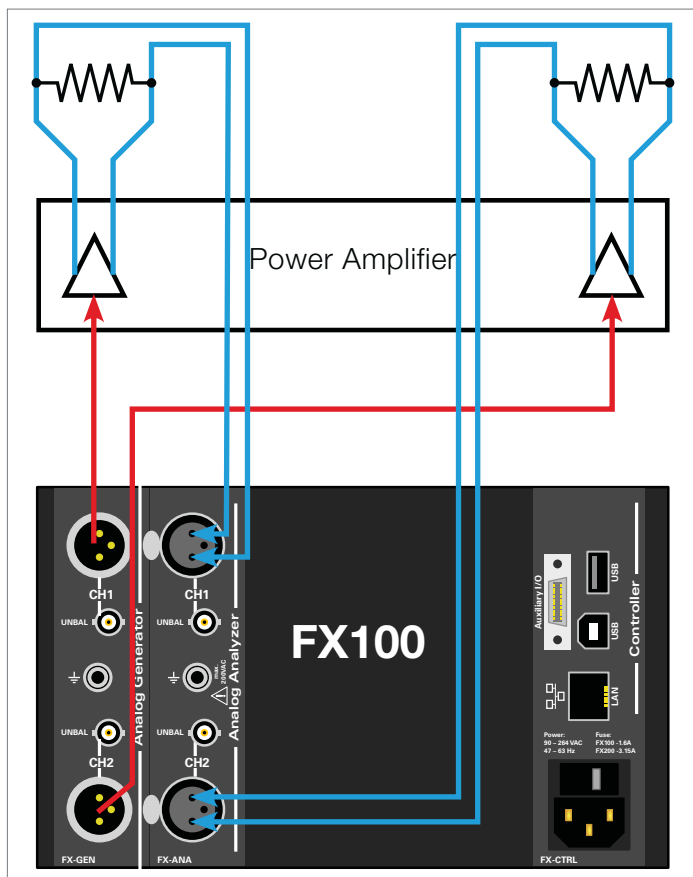

FX100 Test Setup