

Dehumidifier

FOR 1/2" OUTDOOR MEASUREMENT MICROPHONE



For the use of the outdoor measurement microphones (M2230-WP and M2340-WP) in weather-exposed locations with high humidity and temperatures that can cause dew, NTi recommends the TA202 dehumidifier. Due to the high impedance of the microphone capsule, even minimal moisture can affect its performance. The dehumidifier absorbs the moisture before it settles on the capsule, thereby providing accurate measurements, even under highly variable environmental conditions.

The TA202 dehumidifier is mounted between the MA220/MA230 preamplifier and the MC230A microphone capsule. It contains silica gel that effectively removes moisture from the air around the microphone capsule. As the gel absorbs moisture, it changes from its original blue color to a gray-pink hue. A window in the housing of the dehumidifier allows for monitoring the moisture content. For permanently installed, self-sufficient noise monitoring stations, NTi recommends routinely checking the color of the gel every three months.

By heating the TA202 dehumidifier to a maximum of +130 °C for few hours, it can be easily dried out and reused.

Specifications	
Attenuation	0 dB
max. heating to dry out gel	130°C (266°F)
Scope of Supply	<ul style="list-style-type: none"> • WP30/WP40 TA Housing Extension • TA202 Dehumidifier
Dimension (diameter x length)	<ul style="list-style-type: none"> • WP30/WP40 TA Housing Extension 36 x 47 mm (1.4" x 1.9") • TA202 Dehumidifier 12.7 x 39.5 mm (0.5" x 1.6")
Extends WP30/WP40 length by	36 mm (1.4")
Weight	41 g (1.4 oz)
NTi Audio #	Dehumidifier WP30: 600 040 063 Dehumidifier WP40: 600 040 0149



Dehumidifier for Outdoor Measurement Microphone

ASSEMBLY INSTRUCTION

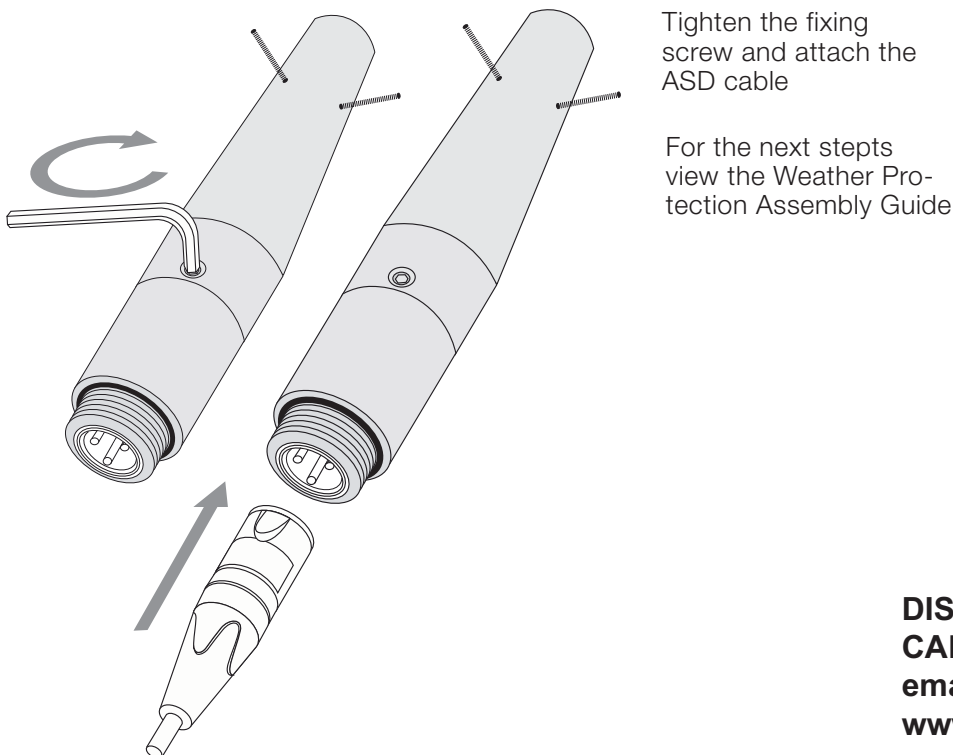
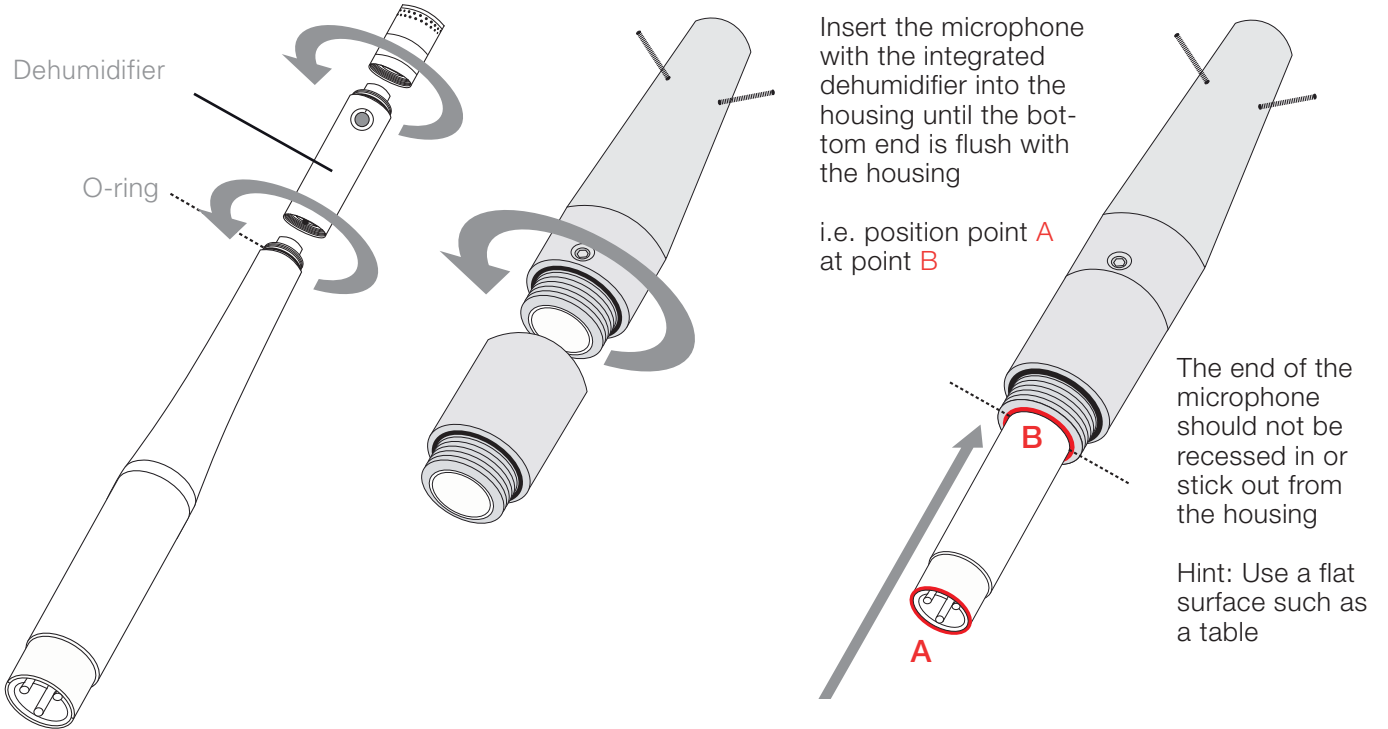

DISTRIBUTOR CONTACT:
CALTRON PTE LTD
 email: caltron@caltron.sg
www.caltron.sg