

## TLP/VF-TLP/HMM HIGH VOLTAGE PULSE GENERATOR

### TLP-8010A

# CMTI, ESD, TLP & VF-TLP SOLUTIONS

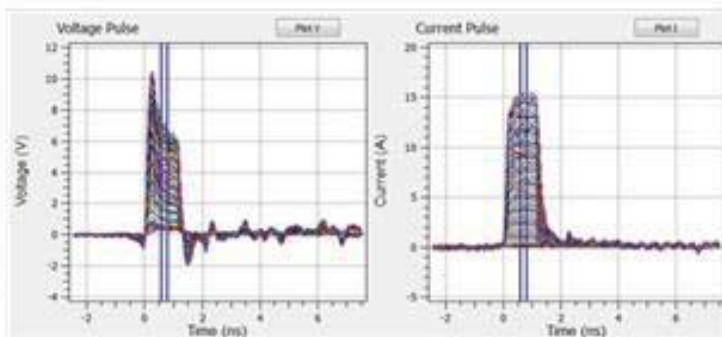
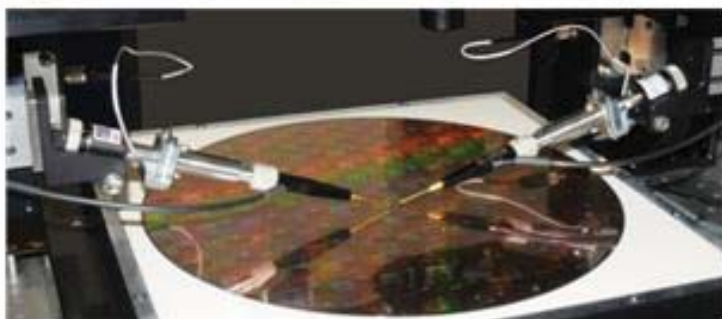
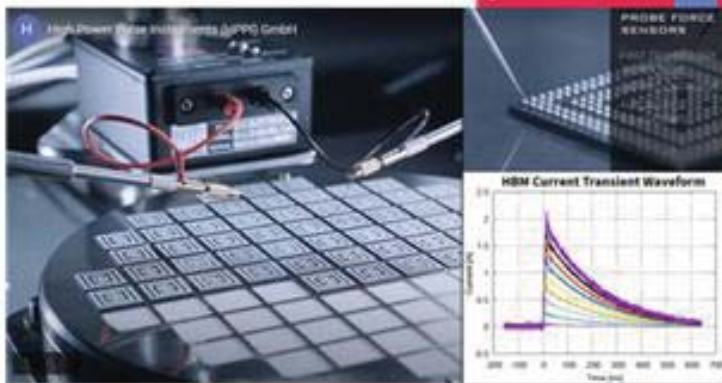

# 80 A High Current TLP/HMM Test System TLP-8010A

Advanced TLP/HMM/HBM Solutions

## 1 Features

- Wafer, package and system level TLP/HMM testing
- Fast 50 Ω high voltage pulse output with typically 300 ps rise time
- Up to 80 kW peak output power into 50 Ω load
- Built-in HMM pulse up to ±15 kV with 100 Ω-configuration
- High pulse output current up to ±80 A (short circuit) with 6 dB reflection suppression
- High speed 50 Ω trigger output for oscilloscopes (synchronous to high voltage pulse output)
- 6 digital programmable pulse rise times: 300 ps to 50 ns
- 1 built-in pulse width: 100 ns
- Optional external pulse width extensions 5/10/50/100/200/500 ns using an external pulse width extender TLP-8012A5
- Fast measurement time, typically 0.2 s per pulse including one-point DC measurement between pulses
- Efficient software for system control and waveform data management
- The software can control automatic probers for fast measurements of complete wafers
- High performance and high quality components



(a) TLP-8010A high voltage pulse generator front side view

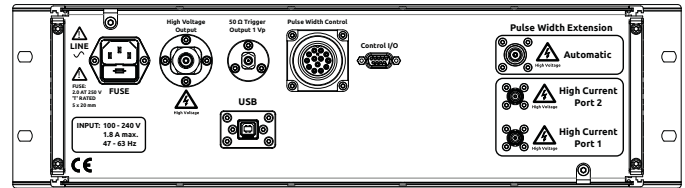

(b) TLP-8010A high voltage pulse generator back side view



(c) 100 A, 50 Ω current sensor CS-0V5-A



(d) 18 GHz DUT switch

Figure 1: TLP-8010A typical system devices

## 2 System Description

The high-current TLP/HMM test system TLP-8010A offers advanced features intended for the characterization of semiconductor devices, discrete components, such as TVS, varistors, capacitors, gas tubes, circuits and systems in the high power time domain. It includes high current I-V characteristics in pulsed operation mode, turn-on/off transient characteristics of the device, breakdown effects, charge recovery effects e.g. reverse recovery, Safe-Operating-Area (SOA) and ESD measurements in general.

The TLP-8010A, Fig. 1, has one built-in pulse width of 100 ns. With the optional TLP-8012A5 pulse width extender the pulse width can be manually extended from 5, 10, 50, 100, 200 up to 500 ns. The system has been optimized for high frequency performance, reliability and highly flexible fast software remote control. The DUT switch shown in Fig. 1(d) automatically connects the DUT to the pulse generator or to the source meter for DC measurements. The advanced current sensor CS-0V5-A, with 150 ps rise-time, can be used up to 100 A at 500 ns pulse width.

The highly efficient software offers best-in-class measurement speed with up to 5 pulses/s, depending on scope and SMU data transfer speed, with one DC spot measurement after every pulse. The software is based on the TLP-3010C platform and offers same features like 4 graphic plots with transient waveforms, DC and I-V data, as well as the I-V data in tab-

ular form. Up to five different data sets can be loaded simultaneously for a direct comparison of devices. Data plots can be copied to the Windows® clipboard and conveniently pasted in other applications. The software offers a calibration routine using zener diodes and resistors as reference. Fig. 2 shows a typical pulse force / pulse sense measurement configuration.

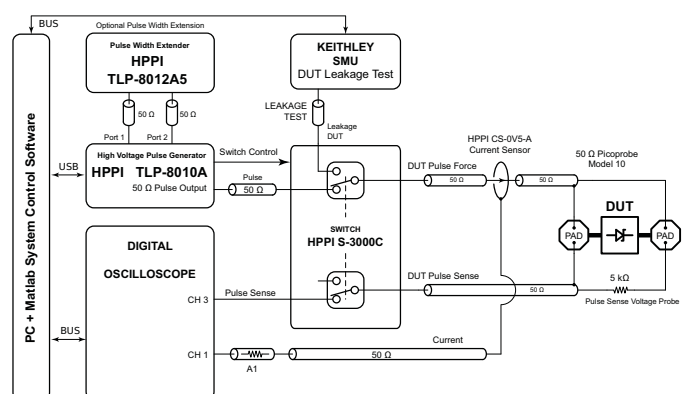

Figure 2: Typical TLP-8010A measurement setup

# 80 A High Current TLP/HMM Test System TLP-8010A

Advanced TLP/HMM/HBM Solutions

## 3 Specifications

Parameter	Symbol	Limit Values			Unit	Remarks
		Min.	Typ.	Max.		
Output voltage (open load)	$V_{out,\infty}$	-4		+4	kV	into open load <sup>1)</sup>
Output voltage (50 Ω load)	$V_{out,50}$	-2		+2	kV	into 50 Ω load
Peak pulse output power (50 Ω load)	$P_{out,50}$		80		kW	into 50 Ω load 6 dB reflection suppression
Minimum output voltage step size	$V_{\Delta}$		0.1		V	into open load, USB progr.
Maximum TLP output current	$I_{tlp}$	-80		+80	A	short circuit 6 dB reflection suppression
Maximum TLP output current	$I_{tlp}$	-57		+57	A	short circuit 12 dB reflection suppression
Maximum TLP output current	$I_{tlp}$	-40		+40	A	50 Ω load
Maximum HMM first peak output current	$I_{peak}$	-57		+57	A	short circuit DUT, 50 Ω HMM
Maximum HMM broad peak output current	$I_{30ns}$	-30		+30	A	short circuit DUT, 50 Ω HMM, equivalent to ±15 kV IEC 61000-4-2 (330 Ω, 150 pF)
Pulse repetition frequency	$f_p$		5	10	Hz	state dependent
Pulse width (typical)	$t_p$		100		ns	one external charge line cable
Pulse width using optional pulse width extender TLP-8012A5 (optional)	$t_p$	5		500	ns	5/10/50/100/200/500 ns manual selectable with TLP-8012A5
Output pulse rise time (typical)	$t_r$	0.3		50	ns	USB programmable 6 steps, out of: 0.3 / 0.6 / 1 / 2 / 5 / 10 / 20 / 50 ns (custom selectable)
Digital control interface	-	USB			-	Industrial isolated and EMI/ESD protected USB 2.0 interface
AC line voltage range	$V_{AC}$	100		240	V	47-63 Hz, max. 1.8 A
Dimensions TLP-8010A (W x H x D)	$D_{8010A}$	428 (482.6) x 132.5 x 485			mm <sup>3</sup>	428 mm body, 482.6 mm rack flange
Weight TLP-8010A	$W_{8010A}$		12		kg	excluding accessories
Software support of digital oscilloscopes	All models from Keysight, LeCroy, Tektronix, Iwatsu. New models will be added on request.					
Software support of SMU source meters	Keithley 24xx/26xx series SMU, Keithley 230 voltage source, Agilent B2900A, Iwatsu. New models will be added on request. 5 SMUs can be controlled by the system: 1 leakage measurement SMU and 4 independent bias SMU.					
Supported automatic probe stations	All Suss, Cascade, Signatone, MPI probe stations					
Supported PC operating system	Microsoft Windows 7-11, 64-bit (required)					
Integrated interlock safety shut-down (optional)	<a href="https://www.hppei.de/files/Interlock_Safety_Shutdown.pdf">https://www.hppei.de/files/Interlock_Safety_Shutdown.pdf</a>					

<sup>1)</sup> The maximum open load output voltage can reach 4 kV. But it is depending on pulse width and it is limited by the breakdown voltage of the SMA connectors. Also at open load condition the DUT voltage should not exceed 2 kV.

## 4 Ordering Information

Pos.	Description	Part No.
01	High voltage pulse generator TLP-8010A including PCB adaptor, current sensor, pick-off tee, DUT switch, cables, software and manuals	TLP-8010A
02	Optional pulse width extender TLP-8012A5 with 6 manual selectable built-in pulse width: 5, 10, 50, 100, 200, 500 ns	TLP-8012A5
03	Precision Picoprobe <sup>®</sup> Micropositioner Probe Holder Kit, customizable for various micromanipulators	PHD-3001A

### General

The product data contained in this data-sheet is exclusively intended for technically trained staff. You and your technical departments will have to evaluate the suitability of the product for the intended application and the completeness of the product data with respect to such application. Our products are solely intended to be commercially used internally and should not be sold to consumers. This data-sheet is describing the specifications of our products for which a warranty is being granted by HPPI GmbH. Any such warranty is granted exclusively pursuant to the terms and conditions of the respective supply agreement. There will be no guarantee of any kind for the product and its specifications. For further information on technology, specific applications of our product, delivery terms, conditions and prices please contact HPPI:

High Power Pulse Instruments GmbH  
 Stadlerstrasse 6A  
 D-85540 Haar, Germany  
 Phone : +49 (0)89 8780698 - 440  
 Fax : +49 (0)89 8780698 - 444  
 E-Mail : [info@hppei.de](mailto:info@hppei.de)

Due to technical requirements our products and/or their application may be harmful. For information please read carefully the manual or contact HPPI. Safety notes in the manual will inform you about possible risks that result from any foreseeable application of our products. Changes of this data-sheet are reserved.