

TLP/VF-TLP/HMM HIGH VOLTAGE PULSE GENERATOR

TLP-4010C

CMTI, ESD, TLP & VF-TLP SOLUTIONS



TLP/VF-TLP/HMM Test System TLP-4010C/3011C

Advanced TLP/HMM/HBM Solutions

1 Features

- Wafer and package level TLP/VF-TLP/HMM testing
- Ultra fast 50 Ω high voltage pulse output with typical 100 ps rise time
- Built-in HMM (IEC 61000-4-2) pulse up to ±10 kV
- High pulse output current up to ±40 A
- High speed 50 Ω trigger output for oscilloscopes (synchronous to high voltage pulse output)
- 6 programmable pulse rise times: 100 ps to 50 ns
- 8 (optional 9) programmable pulse widths: 0.5 ns (optional), 1 ns to 100 ns
- Optional pulse width extender increases pulse width up to 1.6 μs in 68 programmable steps
- Fast measurement time, typically 0.2 s per pulse including one-point DC measurement between pulses
- Efficient software for system control and waveform data management
- The software can control automatic probers (Suss) for fast measurement of complete wafers
- High performance and high quality components

2 System Description

The universal TLP/VF-TLP/HMM test system TLP-4010C/3011C offers advanced features intended for the characterization of circuits, semiconductor devices and discretes like TVS, varistors, capacitors, in the high power time domain. It includes high current I-V characteristics in pulsed operation mode, turn-on/off transient characteristics of the device, breakdown effects, charge recovery effects (e.g. reverse recovery), Safe-Operating-Area (SOA) and ESD measurements. The test system is available in two basic configurations:

1. TLP-4010C high voltage pulse generator (Fig. 1)
2. TLP-4010C high voltage pulse generator combined with TLP-3011C pulse width extender (Fig. 2)

The TLP-4010C has 8 (optional 9) programmable pulse widths from 0.5 ns (optional), 1 ns to 100 ns. 0.5 ns pulse width is optional available. The 0.5 ns pulse width can be useful for advanced CC-TLP or gate oxide reliability investigations.

The optional pulse width extender TLP-3011C (Fig. 2) is used to extend the pulse width up to 1.6 μs in 68 steps. The system has been optimized for high frequency performance, reliability and highly flexible fast software remote control.



(a) TLP-4010C high voltage pulse generator, with optional pulse width extender TLP-3011C

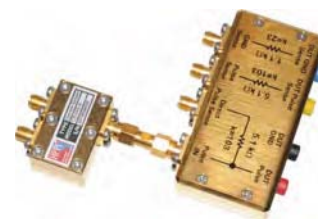

(b) PCB adapter and HPPI current sensor CS-0V5-A



(c) 18 GHz DUT switch

Figure 1: TLP-4010C with optional pulse width extender



Figure 2: TLP-3011C pulse width extender 0.125 - 1.6 μs



Figure 3: Typical output pulse waveform (40 GS/s)

Fig. 3 shows the measured waveform at the 50 Ω pulse output of the TLP-4010C (Fig. 4) recorded using a 12 GHz

TLP/VF-TLP/HMM Test System TLP-4010C/3011C

Advanced TLP/HMM/HBM Solutions

Tektronix® Oscilloscope TDS6124C at 40 GS/s sampling rate. The output pulse shows 100 ps rise time and low ringing. The measurement was performed with the pulse output directly connected to the oscilloscope input using high performance RF cables.



Figure 4: 50 Ω output

Fig. 5 shows typical 100 ns pulses with 800 V output voltage amplitude into 50 Ω load at different rise-time filter settings. The programmable rise times are useful to detect dv/dt dependent triggering of e.g. SCR-based devices or to suppress ringing caused by packaging or PCB parasitic inductance's. The USB programmable pulse widths from 0.5 ns (optional), 1 ns to 1.6 μs in 68 steps enable various device-under-test (DUT) investigations e.g. the Wunsch-Bell characteristic.

The DUT switch (Fig. 1(c)) automatically connects the DUT to the pulse generator or to the source meter for DC measurements.

The HPPI current sensor CS-0V5-A is used for standard TLP measurements. For very-fast TLP measurements <10 ns the software supports TDR algorithms for I/V measurements based on the incident and reflected signals.

The HPPI current sensor CS-0V5-A is used for standard TLP measurements. For very-fast TLP measurements <10 ns the software supports TDR algorithms for I/V measurements based on the incident and reflected signals.

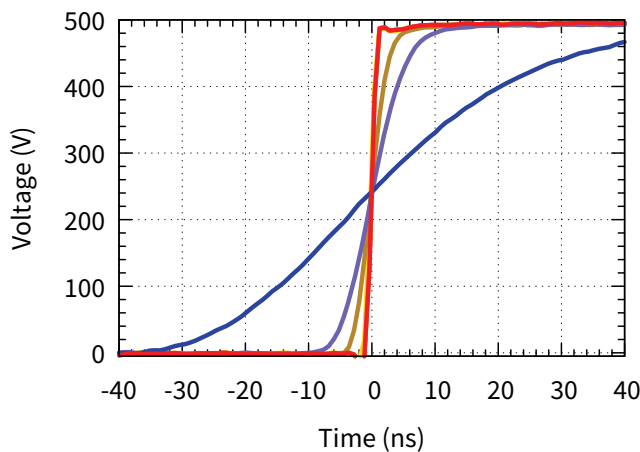

Figure 5: Measured 500 V output pulses into 50 Ω load at different custom rise time filter settings

Fig. 6 shows a photograph of the TLP-4010C/3011C test system including sampling oscilloscope, source meter for DC measurements and control PC. The optional wafer probe station is not shown.

The efficient software offers best-in-class measurement speed with up to 5 pulses/s, depending on scope and SMU data transfer speed, including one DC spot measurement after every pulse. Fig. 7 illustrates the main window of the software. It presents 4 graphic plots with transient waveforms, DC and I-V data, as well as the I-V data in tabular form. Up to

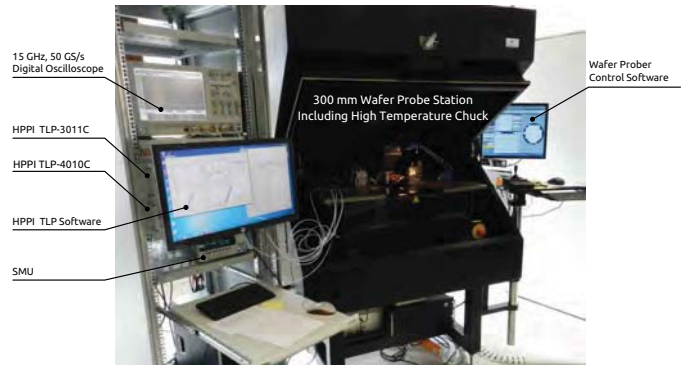

Figure 6: TLP-4010C/3011C test system example

five different data sets can be loaded simultaneously for a direct comparison of devices. Data plots can be copied to the Windows® clipboard and conveniently pasted in other applications. The software offers a calibration routine using zener diodes and resistors as reference. It automatically calibrates each scale step of the oscilloscope to eliminate possible offsets that might appear in the I-V curve when the scope scale is changed by the auto-ranging algorithm. As an option a remote control software interface is available for customers who need to control their existing measurement system remotely.

3 Measurement Techniques

This section gives a brief overview of measurement techniques using the TLP-4010C/3011C TLP/VF-TLP/HMM test system.

3.1 Wafer Level TLP

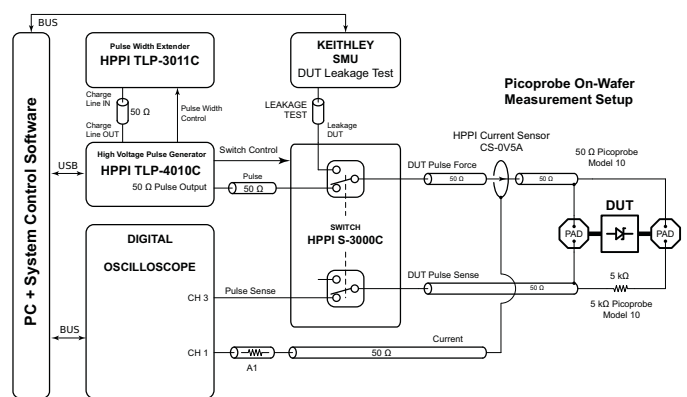

Figure 8: Wafer-level standard TLP setup

Fig. 8 shows the block diagram of a standard wafer-level TLP measurement setup. To eliminate the error from non-zero contact resistance, a four point Kelvin method is preferred to measure the differential voltage directly at the device pads.

TLP/VF-TLP/HMM Test System TLP-4010C/3011C

Advanced TLP/HMM/HBM Solutions

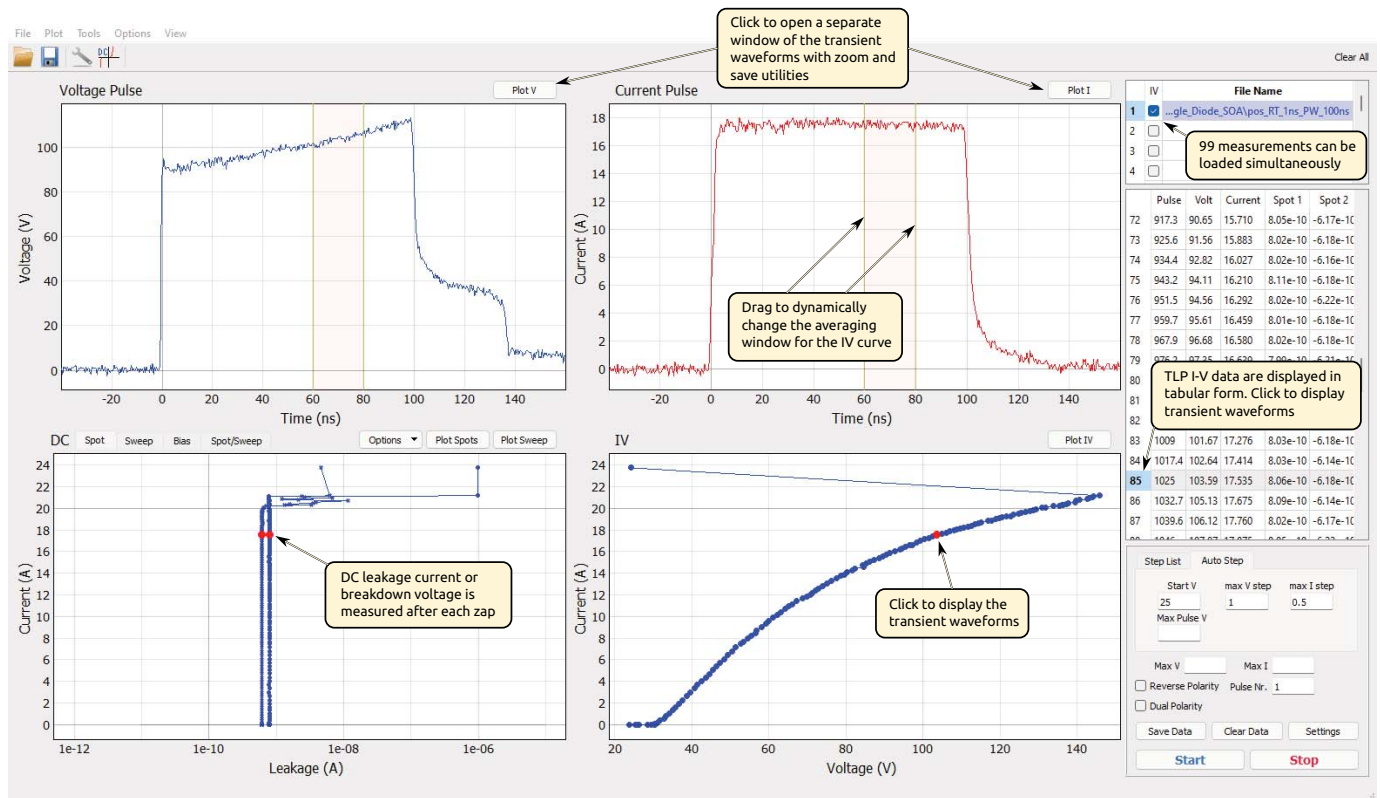

Figure 7: Efficient software for system control and waveform data management

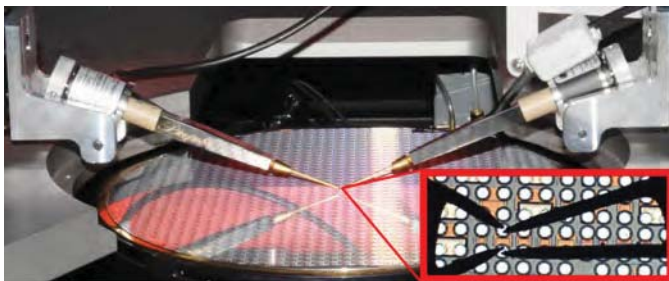

Figure 9: Picoprobe® wafer level TLP/VF-TLP setup

We recommend using RF-probes of type Picoprobe® Model-10, which are the same ones used in our vf-TLP setup. This allows the voltage to be measured with high bandwidth and enables fast switching between standard- and vf-TLP mode.

The sense probe tip has an integrated resistive divider, which enables the voltage to be measured with minimal parasitic loading (1 kΩ - 5 kΩ). Fig. 9 shows a photograph of the Picoprobe® Model-10 force and sense probes, contacting a device with 200 μm pad pitch. The replaceable probe tips can be obtained with user specified pitch from GGB Industries®.

3.2 PCB and Package Level TLP

For package and PCB-level TLP measurements, the PCB adapter shown in Fig. 1(b) is used to contact the DUT with short interconnection wires. A pulse rise time of 10 ns is recommended in order to avoid ringing due to the parasitic inductance of the wires.

ommended in order to avoid ringing due to the parasitic inductance of the wires.

3.3 Very Fast TLP

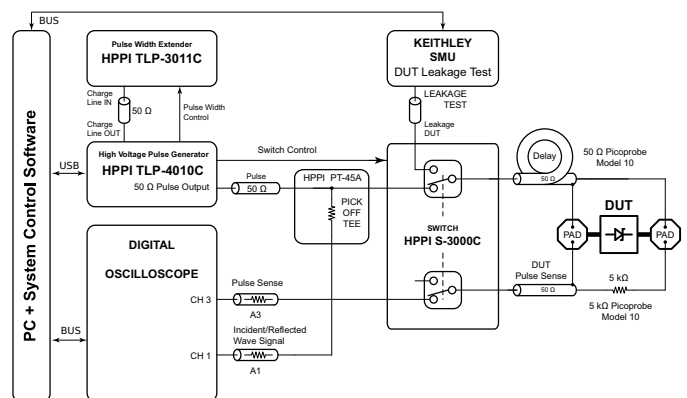

Figure 11: Wafer-level very-fast TLP setup (VF-TLP)

For VF-TLP measurements with pulse widths <10 ns, incident and reflected signals are recorded separately with a wide-band pick-off tee in the pulse-force line (see Fig. 11). The transient device response is calculated by combining the incident and reflected pulse signals numerically (TDR-s method). The device voltage is preferably measured directly with a second Picoprobe model-10 with integrated voltage dividing resistor.

3.6 Charge Recovery Time

In addition the test system TLP-4010C/3011C offers a measurement setup for charge recovery measurements like forward and reverse recovery time of diodes. In contrast to existing measurement techniques the recovery times can be measured extremely fast and efficient in the range from about 200 ps up to 1 μ s. The DUT is mounted in a true 50 Ω test fixture.

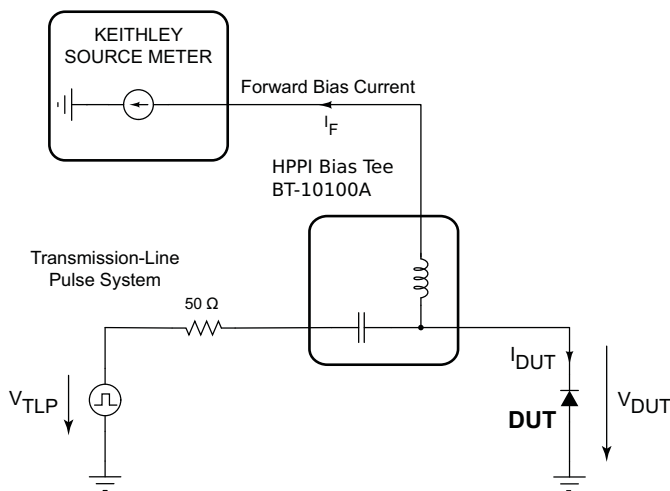

Figure 14: 50 Ω recovery measurement setup

Fig. 14 shows the block diagram of a 50 Ω recovery measurement setup. The DUT is operated with 50 Ω source resistance. The setup can be used for reverse as well as forward recovery time measurements. The DUT voltage is measured with a wideband pick-off tee. For expected recovery times <2 ns the DUT current is extracted using a VF-TLP setup. For expected recovery times >2 ns the DUT current can be measured directly with the fast-rise-time HPPI CS-0V5-A current sensor in a classical TLP setup.

To operate the DUT with a 100 Ω source resistance a 50 Ω resistor can be easily connected in series with the DUT. 50 Ω source resistance of the TLP-4010C and 50 Ω load resistance of the DUT results in total 100 Ω . In this case the DUT will be operated into a 50 Ω load or attenuator. The DUT current can be measured directly with the 50 Ω sampling oscilloscope input.

Fig. 15 shows typical reverse recovery measurement waveforms. The extraction of the reverse recovery time t_{rr} can be done as follows:

1. Set the TLP-4010C pulse parameters to 100 ps rise time and a pulse width which is approximately two to three times the expected reverse recovery time.
2. Operate diode in forward mode with a specified forward bias current I_F .

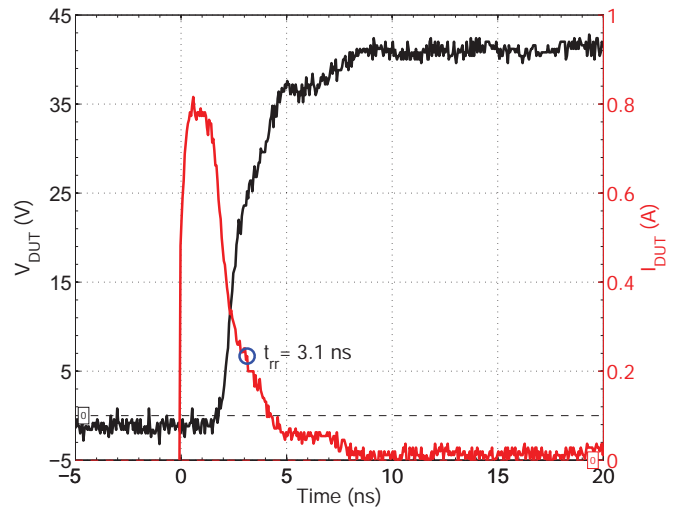

Figure 15: Measured reverse recovery waveforms

3. Apply a reverse mode TLP pulse with a defined reverse voltage $V_R = V_{TLP} - |V_F|$. The Voltage V_R is measured using the mean value between 70 % and 80 % of the TLP pulse width at the device (V_{DUT}).
4. Measurement of the nominal peak reverse current.
5. Extract 25 % of the nominal peak reverse current.
6. The time where the current I_{DUT} decreases down to 25 % of the nominal peak reverse current is the reverse recovery time.

Fig. 16 shows the result which can be achieved just by three classical TLP sweeps:

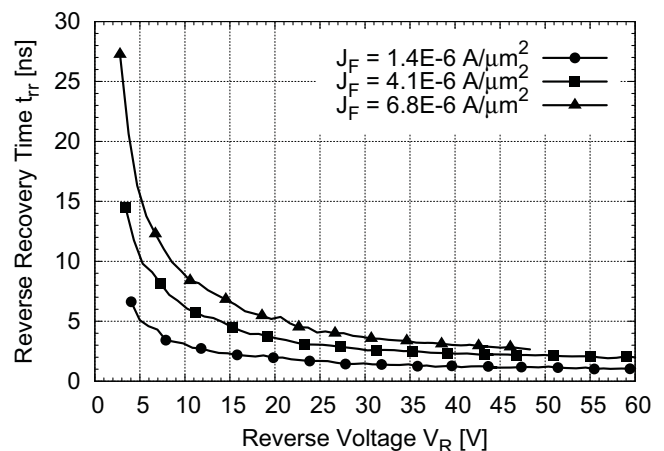

Figure 16: TLP extracted reverse recovery time

TLP/VF-TLP/HMM Test System TLP-4010C/3011C

Advanced TLP/HMM/HBM Solutions

4 TLP-4010C/3011C Front and Rear Panel Connectors

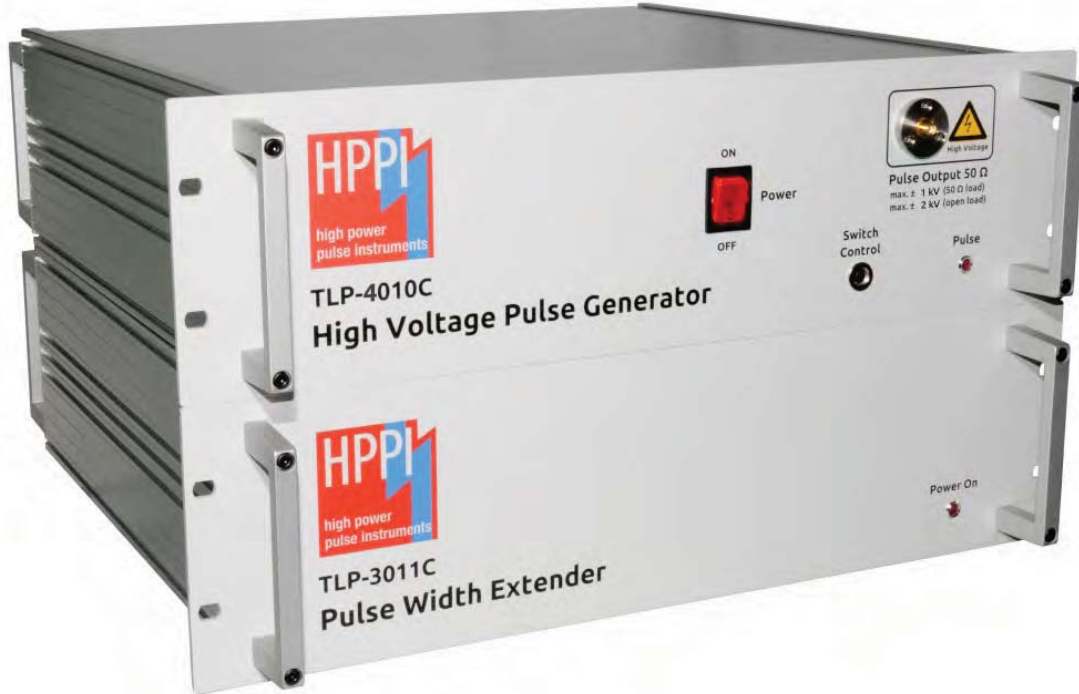

Figure 17: TLP-4010C/3011C front panel electrical connections

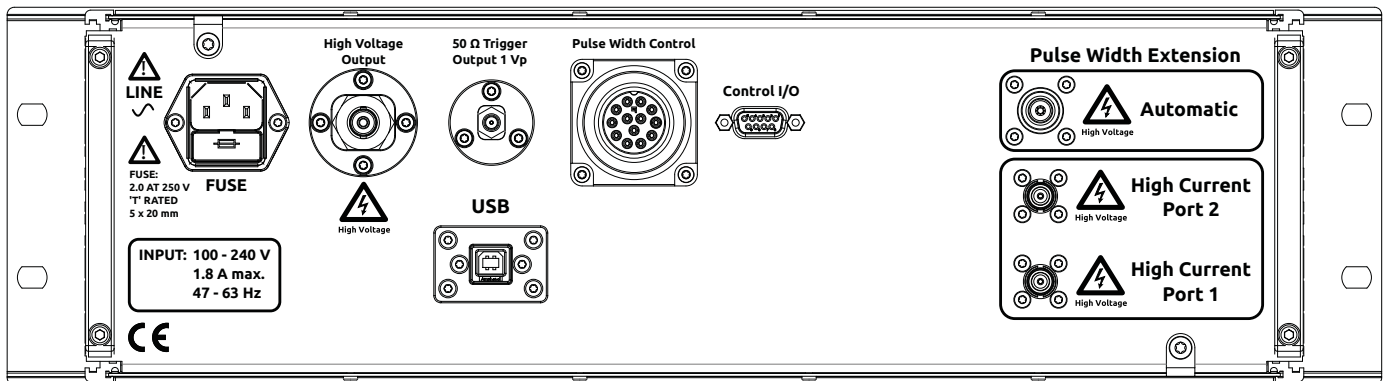

Figure 18: TLP-4010C rear panel electrical connections

5 Specifications

Parameter	Symbol	Limit Values			Unit	Remarks
		Min.	Typ.	Max.		
Output voltage (open load)	$V_{out,\infty}$	-2.0		+2.0	kV	into open load
Output voltage (50 Ω load)	$V_{out,50}$	-1.0		+1.0	kV	into 50 Ω load
Peak pulse output power (50 Ω load)	$P_{out,50}$		20		kW	into 50 Ω load
Minimum output voltage step size	V_{Δ}		0.1		V	into open load, USB progr.

Table continued on next page ...

TLP/VF-TLP/HMM Test System TLP-4010C/3011C

Advanced TLP/HMM/HBM Solutions

... Table continued from previous page

Parameter	Symbol	Limit Values			Unit	Remarks
		Min.	Typ.	Max.		
Maximum TLP output current	I_{tlp}	-40		+40	A	short circuit 12 dB reflection suppression
Maximum TLP output current	I_{tlp}	-20		+20	A	50 Ω load
Maximum HMM first peak output current	I_{peak}	-38		+38	A	short circuit DUT, 50 Ω HMM
Maximum HMM broad peak output current	I_{30ns}	-20		+20	A	short circuit DUT, 50 Ω HMM, equivalent to ± 10 kV IEC 61000-4-2 (330 Ω , 150 pF)
Output pulse rise time	t_r	0.1		50	ns	USB programmable 6 steps, out of: 0.1 / 0.3 / 0.6 / 1 / 2 / 5 / 10 / 20 / 50 ns (custom selectable)
Pulse width base unit TLP-4010C (typical)	t_p	0.5 ¹ or 1		100	ns	USB programmable in 8 or 9 ¹ steps: 0.5 ¹ / 1 / 2.5 / 5 / 10 / 25 / 50 / 75 / 100 ns
Pulse width with optional extender TLP-3011C (typ.)	t_p	125		1600	ns	USB programmable in 68 steps: 125 - 1600 ns in 25 ns steps
Pulse repetition frequency	f_p		5	10	Hz	state dependent
Digital control interface	-	USB			-	Industrial isolated and EMI/ESD protected USB 2.0 interface
AC line voltage range	V_{AC}	100		240	V	47-63 Hz, max. 1.8 A
Dimensions TLP-4010C (W x H x D)	D_{4010C}	428 (482.6) x 132.5 x 485			mm ³	428 mm body, 482.6 mm rack flange
Dimensions TLP-3011C (W x H x D)	D_{3011C}	428 (482.6) x 132.5 x 485			mm ³	428 mm body, 482.6 mm rack flange
Weight TLP-4010C	W_{4010C}		13.5		kg	excluding accessories
Weight TLP-3011C	W_{3011C}		15.2		kg	excluding accessories
Software support of digital oscilloscopes	All models from Keysight, LeCroy, Tektronix, Iwatsu. New models will be added on request.					
Software support of SMU source meters	Keithley 24xx/26xx series SMU, Keithley 230 voltage source, Agilent B2900A, Iwatsu. New models will be added on request. 5 SMUs can be controlled by the system: 1 leakage measurement SMU and 4 independent bias SMU.					
Supported automatic probe stations	All Suss, Cascade, Signatone, MPI probe stations					
Supported PC operating system	Microsoft Windows 7-11, 64-bit (required)					
Integrated interlock safety shut-down (optional)	https://www.hppi.de/files/Interlock_Safety_Shutdown.pdf					

¹0.5 ns pulse width is optional available.

6 Ordering Information

Pos.	Description	Part No.
01	High voltage pulse generator TLP-4010C including PCB adapter, current sensor, pick-off tee, DUT switch, cables, software and manuals	TLP-4010C
02	Optional pulse width extender TLP-3011C	TLP-3011C
03	Precision Picoprobe [®] Micropositioner Probe Holder Kit (Fig. 9), customizable for various micropositioners	PHD-3001A

General

The product data contained in this data-sheet is exclusively intended for technically trained staff. You and your technical departments will have to evaluate the suitability of the product for the intended application and the completeness of the product data with respect to such application. Our products are solely intended to be commercially used internally and should not be sold to consumers. This data-sheet is describing the specifications of our products for which a warranty is being granted by HPPI GmbH. Any such warranty is granted exclusively pursuant to the terms and conditions of the respective supply agreement. There will be no guarantee of any kind for the product and its specifications. For further information on technology, specific applications of our product, delivery terms, conditions and prices please contact HPPI:

High Power Pulse Instruments GmbH
 Stadlerstrasse 6A
 D-85540 Haar, Germany
 Phone : +49 (0)89 8780698 - 440
 Fax : +49 (0)89 8780698 - 444
 E-Mail : info@hppi.de

Due to technical requirements our products and/or their application may be harmful. For information please read carefully the manual or contact HPPI. Safety notes in the manual will inform you about possible risks that result from any foreseeable application of our products. Changes of this data-sheet are reserved.