

TLP/VF-TLP/HMM HIGH VOLTAGE PULSE GENERATOR

TLP-12010C

CMTI, ESD, TLP & VF-TLP SOLUTIONS

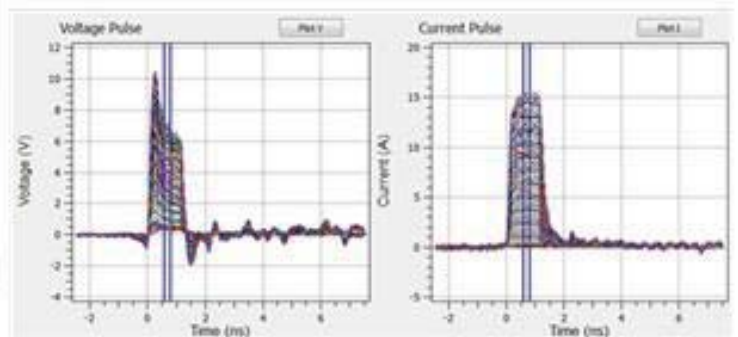
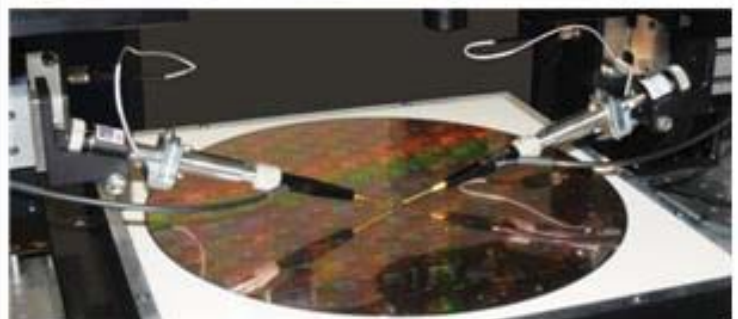
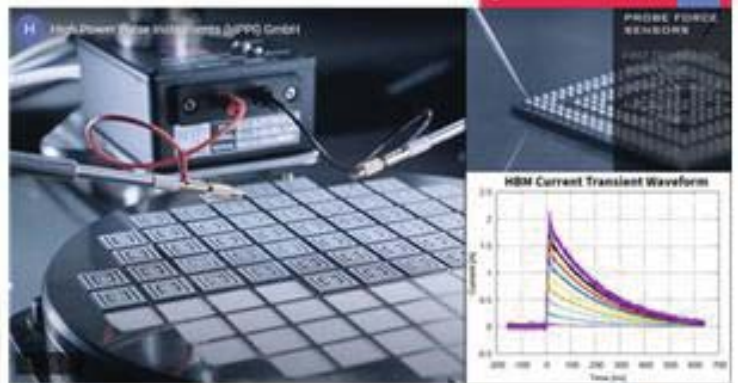

120 A TLP/VF-TLP/HMM Test System TLP-12010C

Advanced TLP/HMM/HBM Solutions

1 Features

- High pulse output current up to ± 120 A (short circuit)
- Ultra-fast 50 Ω high voltage pulse output with typical rise time 100 ps (0 A to 40 A) and 300 ps in high-current mode (0 A to 120 A)
- Wafer, package and system level TLP, VF-TLP and HMM testing
- Up to 180 kW peak output power into 50 Ω load
- Built-in HMM pulse up to ± 32 kV in 50 Ω -configuration
- High speed 50 Ω trigger output for oscilloscopes (synchronous to high voltage pulse output)
- 6 digital programmable pulse rise times: 100 ps to 50 ns
- 8 (optional 9) programmable pulse widths: 0.5 ns (optional), 1 ns to 100 ns (0 A to 40 A), 1 built-in pulse width: 100 ns (0 A to 120 A)
- The optional pulse width extender TLP-3011C enables pulse width up to 1.6 μ s in 68 digital programmable steps (0 A to 40 A)
- Optional external pulse width extensions from 5 ns to 500 ns (0 A to 120 A) using the external pulse width extender TLP-12012A6
- Built-in pulse reflection suppression
- Fast measurement time, typically less than 0.2 s per pulse including one-point DC measurement between pulses
- Efficient software for system control and waveform data management
- The software can control automatic probers for fast measurements of complete wafers
- Combines TLP-12010A and TLP-4010C into one system
- Can be operated together with TLP-12012A6 and TLP-3011C pulse width extenders
- Integrated interlock safety shut-down
- Industrial isolated and EMI/ESD protected USB control interface

2 System Description

The high-current TLP/VF-TLP/HMM test system TLP-12010C combines the performance of the TLP-12010A and TLP-4010C system. It offers advanced features intended for the characterization of semiconductor devices, discrete components, such as TVS, varistors, capacitors, gas tubes, circuits and systems in the high power time domain. It includes high current I-V characteristics in pulsed operation mode, turn-on/off transient characteristics of the device, breakdown effects, charge recovery effects e.g. reverse recovery, Safe-Operating-Area (SOA) and ESD measurements in general.

The TLP-12010C, Fig. 1, has 8 (optional 9) programmable pulse widths 0.5 ns (optional), 1 ns to 100 ns (0 A to 40 A) and 1 built-in pulse width 100 ns for currents 0 A to 120 A.

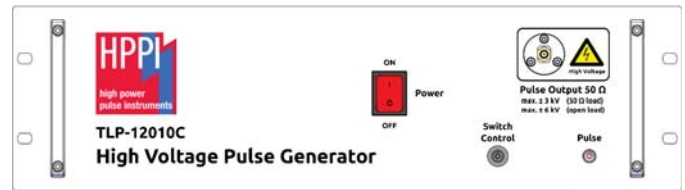

(a) TLP-12010C high voltage pulse generator front side view

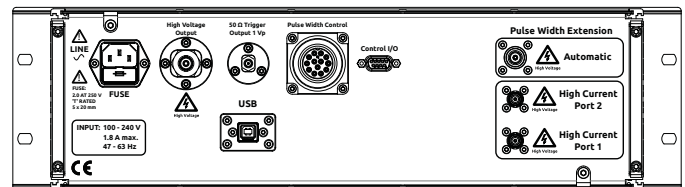

(b) TLP-12010C high voltage pulse generator rear side view



(c) 120 A, 50 Ω current sensor CS-0V5-A



(d) 18 GHz DUT switch S-3000D

Figure 1: TLP-12010C overview

Since the TLP-12010C in the current regime up to 120 A is limited to just one single pulse width the TLP-12012A6 pulse width extender may be considered. With this optional extender additional pulse width of 5, 10, 50, 100, 200 and 500 ns for example can be generated.

In contrast to the TLP-4010C the selection is done manually. Using the optional pulse width extender TLP-3011C the pulse width can be increased automatically up to 1.6 μ s in 68 digital programmable steps from 0 A to 40 A. The TLP-12010C can be combined and operated together with the TLP-12012A6 and TLP-3011C extenders. The system has been optimized for high frequency performance, reliability and highly flexible fast software remote control.

The DUT switch shown in Fig. 1(d) automatically connects the DUT to the pulse generator or to the source meter for DC measurements.

The advanced current sensor CS-0V5-A, with 150 ps rise-time, can be used up to e.g. 120 A at 580 ns pulse width or 100 A at 700 ns pulse width, according to its Amp x Second rating of 70 A μ s, respectively.

The highly efficient TLP software offers best-in-class measurement speed with up to 5 pulses/s, depending on scope and SMU data transfer speed, with one DC spot measurement after every pulse. The software is based on the TLP-3010C/4010C platform and offers seamless control and enhanced features like 4 graphic plots with transient waveforms, DC and I-V data, as well as the I-V data in tabular form. Up to five different data sets can be loaded simultaneously for a direct comparison of devices.

120 A TLP/VF-TLP/HMM Test System TLP-12010C

Advanced TLP/HMM/HBM Solutions

Data plots can be copied to the Windows® clipboard and conveniently pasted in other applications. The software offers accurate TLP full system calibration using zener-diodes and resistors as reference.

For compliance with laboratory safety regulations an interlock shut-down function has been integrated according: https://www.hppi.de/files/Interlock_Safety_Shutdown.pdf

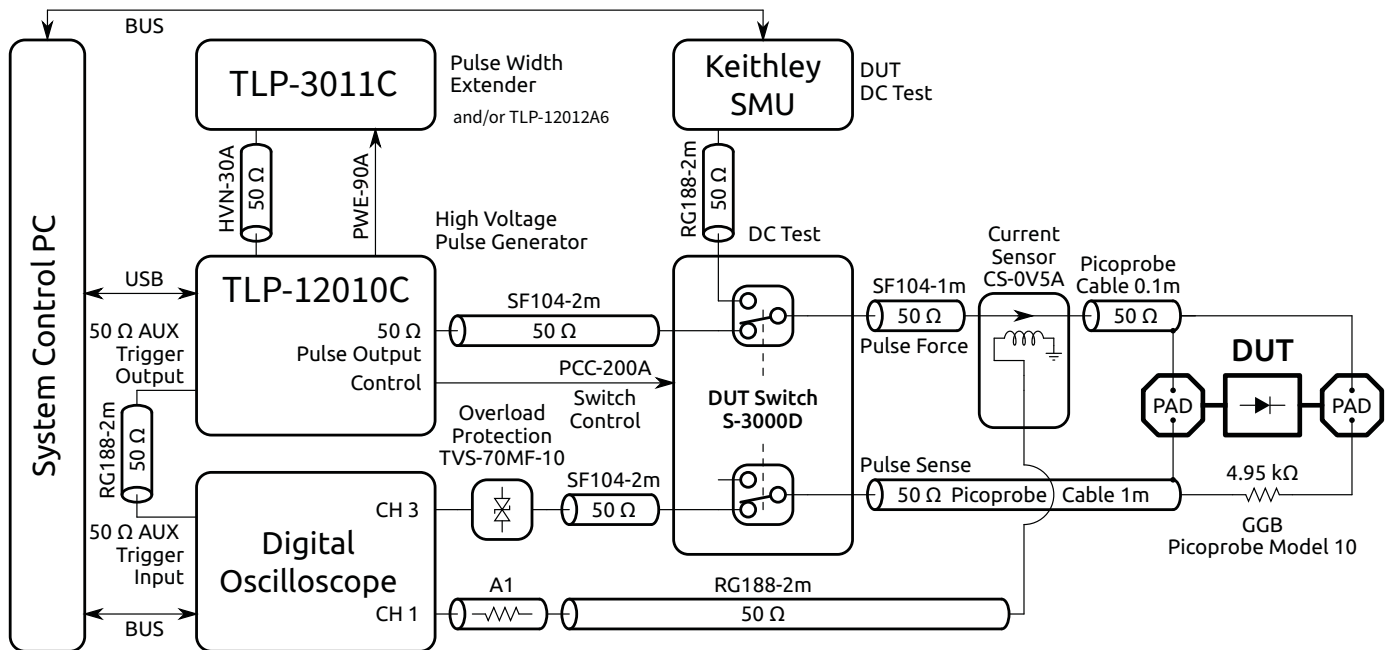

Figure 2: Typical TLP-12010C standard TLP measurement setup

Fig. 2 shows a typical pulse force / pulse sense measurement configuration.

3 TLP-12010C Specifications

Parameter	Symbol	Limit Values			Unit	Remarks
		Min.	Typ.	Max.		
Output voltage (open load)	$V_{out,\infty}$	-6.0		+6.0	kV	into open load ¹⁾
Output voltage (50 Ω)	$V_{out,50\Omega}$	-3.0		+3.0	kV	into 50 Ω ²⁾
Peak pulse output power (50 Ω)	$P_{out,50\Omega}$		180		kW	into 50 Ω ³⁾
Minimum output voltage step size	V_{Δ}		0.1		V	into open load, USB progr.
Maximum TLP output current	I_{tlp}	-120		+120	A	into short circuit
Maximum TLP output current	I_{tlp}	-60		+60	A	into 50 Ω
Maximum HMM first peak output current	I_{peak}	-120		+120	A	short circuit DUT, 50 Ω HMM
Maximum HMM broad peak output current	I_{30ns}	-64		+64	A	short circuit DUT, 50 Ω HMM, equivalent to ± 32 kV IEC 61000-4-2 (330 Ω , 150 pF)
Pulse repetition frequency	f_p		5	10	Hz	state dependent
Pulse width in 120 A mode	$t_{p,120A}$		100		ns	one internal charge line cable
Pulse width in 120 A mode using pulse width extender TLP-12012A6 (optional)	$t_{p,120A}$	5		500	ns	5/10/50/100/200/500 ns manual selectable with TLP-12012A6

Table continued on next page ...

¹⁾The maximum open load output voltage could reach 6.0 kV according the internal charge-line voltage setting. But in reality the output voltage it is limited by the breakdown voltage of the SMA connectors and other interconnection devices towards the DUT. Therefore, at open load condition the pulse voltage setting should not exceed the interconnection limits. This means that the TLP-12010C should not operated with maximum voltage at open load condition.

²⁾Limited by the breakdown voltage of the DUT connectors.

³⁾Limited by the breakdown voltage and the thermal capability (pulse width) of the DUT connectors.

120 A TLP/VF-TLP/HMM Test System TLP-12010C

Advanced TLP/HMM/HBM Solutions

... Table continued from previous page

Parameter	Symbol	Limit Values			Unit	Remarks
		Min.	Typ.	Max.		
Pulse width in 40 A mode	$t_{p,40A}$	0.5 ¹⁾ or 1		100	ns	USB programmable in 8 or 9 ¹⁾ steps: 0.5 ¹⁾ / 1 / 2.5 / 5 / 10 / 25 / 50 / 75 / 100 ns
Pulse width in 40 A mode using pulse width extender TLP-3011C (optional)	$t_{p,40A}$	125		1600	ns	USB programmable in 68 steps: 125 - 1600 ns in 25 ns steps
Output pulse rise time (40 A mode)	$t_{r,40A}$	0.1		50	ns	USB programmable 6 steps, out of: 0.1 / 0.3 / 0.6 / 1 / 2 / 5 / 10 / 20 / 50 ns (custom selectable)
Output pulse rise time (120 A mode)	$t_{r,120A}$	0.3		50	ns	USB programmable 6 steps, out of: 0.3 / 0.6 / 1 / 2 / 5 / 10 / 20 / 50 ns (rise times >0.3 ns are fixed by the 40 A customer selected configuration)
Digital control interface	-	USB			-	Industrial isolated and EMI/ESD protected USB 2.0 interface
AC line voltage range	V_{AC}	100		240	V	47-63 Hz, max. 1.8 A
Dimensions TLP-12010C (W x H x D)	D_{12010C}	428 (482.6) x 132.5 x 485			mm ³	428 mm body, 482.6 mm rack flange
Weight TLP-12010C	W_{12010C}		15.8		kg	excluding accessories
Software support of digital oscilloscopes	All models from Keysight, LeCroy, Tektronix, Iwatsu. New models will be added on request.					
Software support of SMU source meters	Keithley 24xx/26xx series SMU, Keithley 230 voltage source, Agilent B2900A, Iwatsu. New models will be added on request. 5 SMUs can be controlled by the system: 1 leakage measurement SMU and 4 independent bias SMU.					
Supported automatic probe stations	All Suss, Cascade, Signatone, MPI probe stations					
Supported PC operating system	Microsoft Windows 7-11, 64-bit (required)					
Integrated interlock safety shut-down (optional)	https://www.hppi.de/files/Interlock_Safety_Shutdown.pdf					

¹⁾0.5 ns pulse width is optional available.

Table 1: TLP-12010C specifications

4 Ordering Information

Pos.	Description	Part No.
01	High voltage pulse generator TLP-12010C including PCB adaptor, current sensor, pick-off tee, DUT switch, cables, software and manuals	TLP-12010C
02	Optional 40 A automatic pulse width extender TLP-3011C with 125 μ s to 1.6 μ s in 68 programmable steps	TLP-3011C
03	Optional 120 A pulse width extender TLP-12012A6 with 6 manual selectable built-in pulse width: 5, 10, 50, 100, 200, 500 ns (optional up to 2 μ s on request)	TLP-12012A6
04	Precision Picoprobe [®] Micropositioner Kit PHD-3001A, customizable for various micromanipulators	PHD-3001A

General

The product data contained in this data-sheet is exclusively intended for technically trained staff. You and your technical departments will have to evaluate the suitability of the product for the intended application and the completeness of the product data with respect to such application. Our products are solely intended to be commercially used internally and should not be sold to consumers. This data-sheet is describing the specifications of our products for which a warranty is being granted by HPPI GmbH. Any such warranty is granted exclusively pursuant to the terms and conditions of the respective supply agreement. There will be no guarantee of any kind for the product and its specifications. For further information on technology, specific applications of our product, delivery terms, conditions and prices please contact HPPI:

High Power Pulse Instruments GmbH
 Stadlerstrasse 6A
 D-85540 Haar, Germany
 Phone : +49 (0)89 8780698 - 440
 Fax : +49 (0)89 8780698 - 444
 E-Mail : info@hppi.de

Due to technical requirements our products and/or their application may be harmful. For information please read carefully the manual or contact HPPI. Safety notes in the manual will inform you about possible risks that result from any foreseeable application of our products. Changes of this data-sheet are reserved.