

RISE TIME EXTENDER

RTE-24A

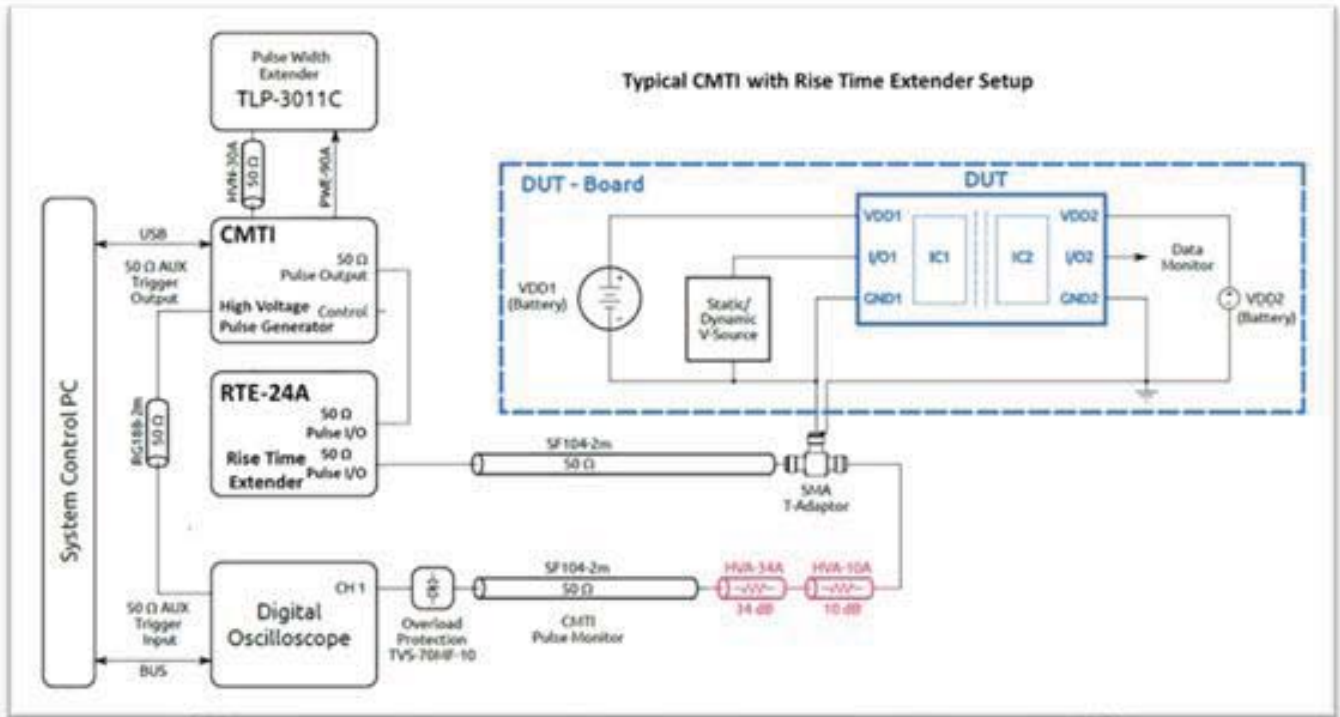

Rise Time Extender RTE-24A

Advanced TLP/HMM/HBM Solutions

1 Features

- Rise time extender with pulse shaping for transmission line pulse (TLP) and common-mode- transfer-immunity (CMTI) pulse generators
- Up to 24 software programmable rise times in the standard range of 100 ps to 50 ns (customizable). Maximum upper limit around 1200 ns on request.
- ± 3 kV pulse voltage at 50Ω
- Software driver for remote control and Graphical User Interface (GUI)
- Industrial isolated and EMI/ESD protected USB control interface

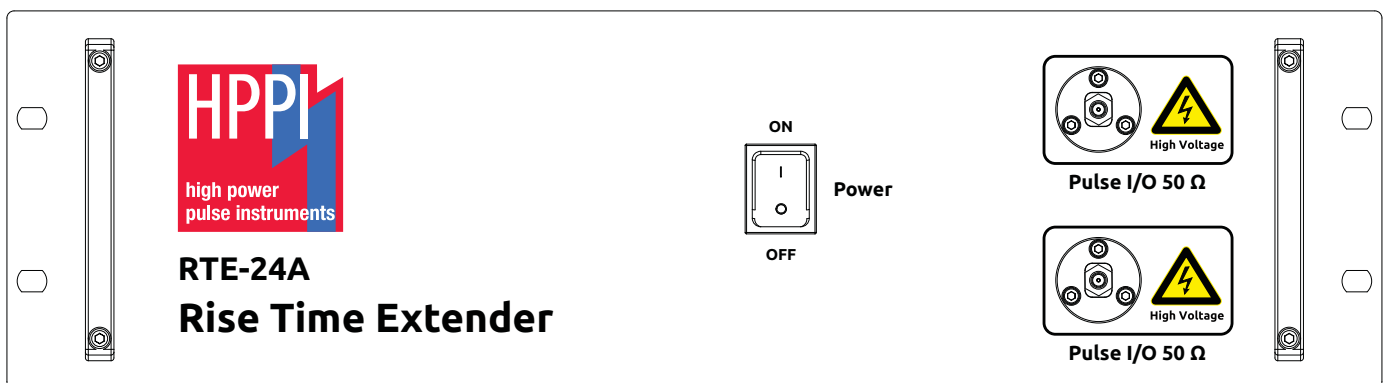

Figure 1: RTE-24A front side view

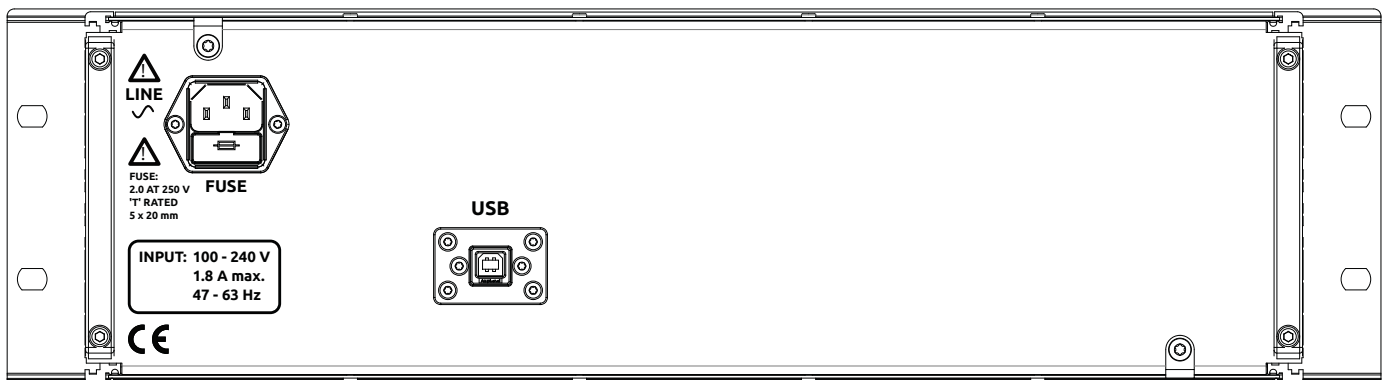

Figure 2: RTE-24A rear side view

2 Introduction

The rise time extender RTE-24A is compatible with all TLP and CMTI pulse generators. It is used to set the rise time of the pulse by automated software control.

State of the art isolated data transmission couplers and isolated gated drivers require CMTI performance tests at pulse slew rates in the range of 50 V ns^{-1} s up to 250 V ns^{-1} or even beyond. While IGBTs are at the lower end of the CMTI necessities, SiC and GaN require CMTI performances above 150 V ns^{-1} . High performance capacitive couplers can reach 250 V ns^{-1} , while magnetic couplers can surpass this performance easily. The weakest CMTI performance is offered by opto-couplers.

Tab. 1 reflects the recommended range of slew rates in the green fields. These slew rates map to a number of 25 rise times for the pulse shaping. As a result a HPPI CMTI tester can cover maximum $24 + 6$ (optional 8) = 30 (optional 32) rise times.

Rise Time Extender RTE-24A

Advanced TLP/HMM/HBM Solutions

			GaN, Super-Junction MOSFET			Automotive, Solar IGBT, SiC	Solar, Fork Lift, Welding SiC, IGBT		
		CMTI [V _p /ns]	VIORM [V _p]						
			600	800	1000	1420	1800	2000	2200
1	Rise-Time [ns]	0,6	1000	1333	1667	2367	3000	3333	3667
2		1	600	800	1000	1420	1800	2000	2200
3		1,5	400	533	667	947	1200	1333	1467
4		2	300	400	500	710	900	1000	1100
5		2,25	267	356	444	631	800	889	978
6		2,5	240	320	400	568	720	800	880
7		3	200	267	333	473	600	667	733
8		3,25	185	246	308	437	554	615	677
9		3,5	171	229	286	406	514	571	629
10		4	150	200	250	355	450	500	550
11		4,5	133	178	222	316	400	444	489
12		5	120	160	200	284	360	400	440
13		5,5	109	145	182	258	327	364	400
14		6	100	133	167	237	300	333	367
15		7	86	114	143	203	257	286	314
16		8	75	100	125	178	225	250	275
17		9	67	89	111	158	200	222	244
18		10	60	80	100	142	180	200	220
19		11	55	73	91	129	164	182	200
20		12	50	67	83	118	150	167	183
21		14	43	57	71	101	129	143	157
22		15	40	53	67	95	120	133	147
23		17,5	34	46	57	81	103	114	126
24		20	30	40	50	71	90	100	110
25		30	20	27	33	47	60	67	73
26		35	17	23	29	41	51	57	63
27		40	15	20	25	36	45	50	55
28		55	11	15	18	26	33	36	40

Table 1: Preferred CMTI slew rate to pulse rise time mapping for typical isolated data transmission coupler product applications

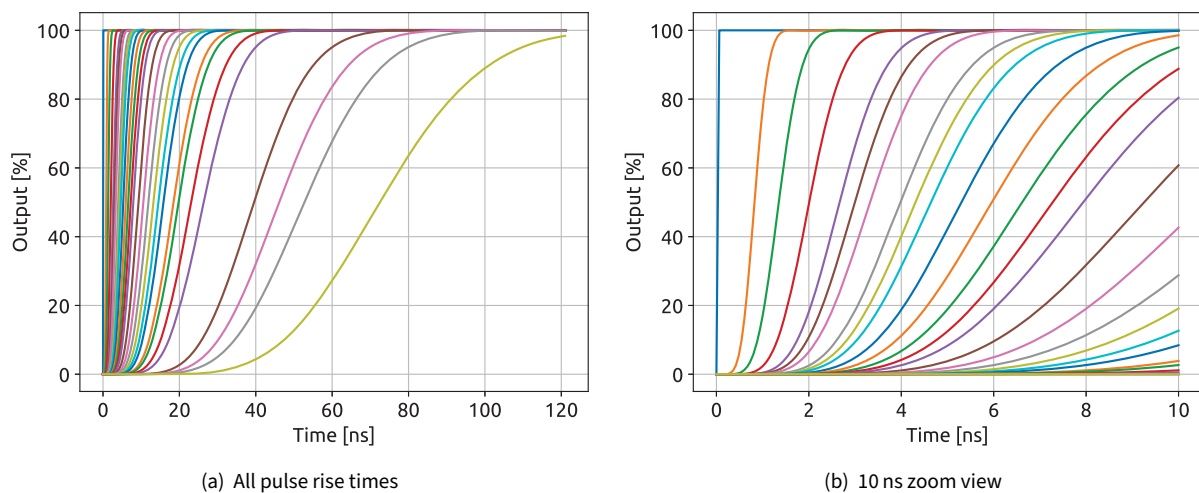

Figure 3: Software programmable rise times

Rise Time Extender RTE-24A

Advanced TLP/HMM/HBM Solutions

2.1 Measurement Setup

The RTE-24A is always connected in series with the pulse generator at its pulse output. Fig. 4 to Fig. 6 show typical static and dynamic CMTI measurement setups.

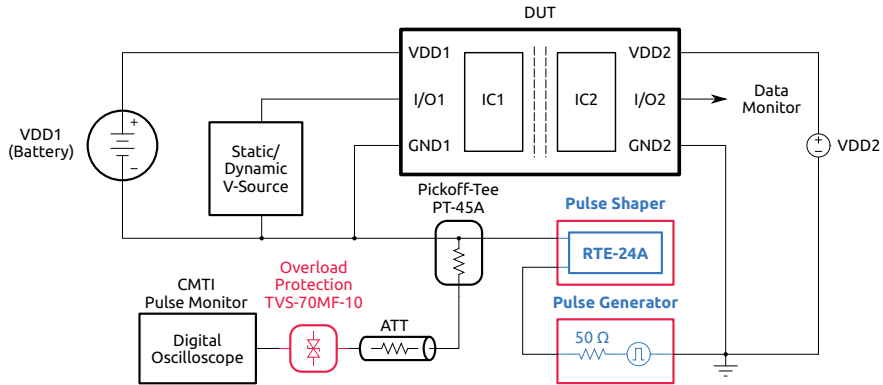

Figure 4: Static open load measurement setup including monitoring

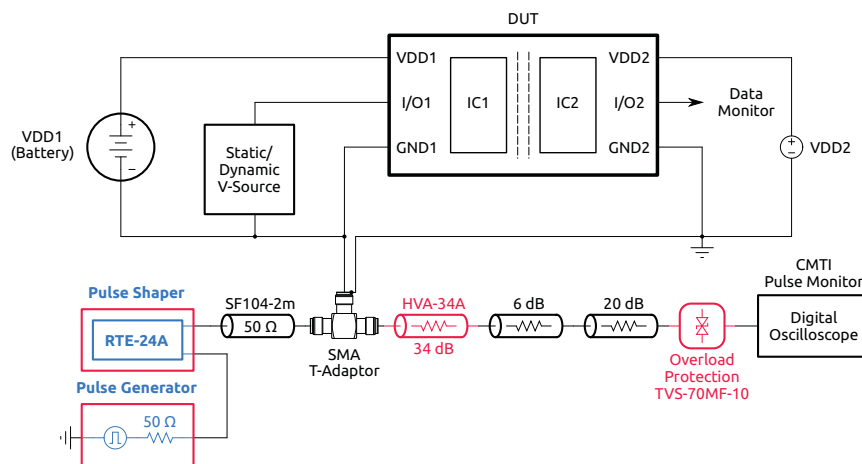

Figure 5: Static terminated load measurement setup including monitoring

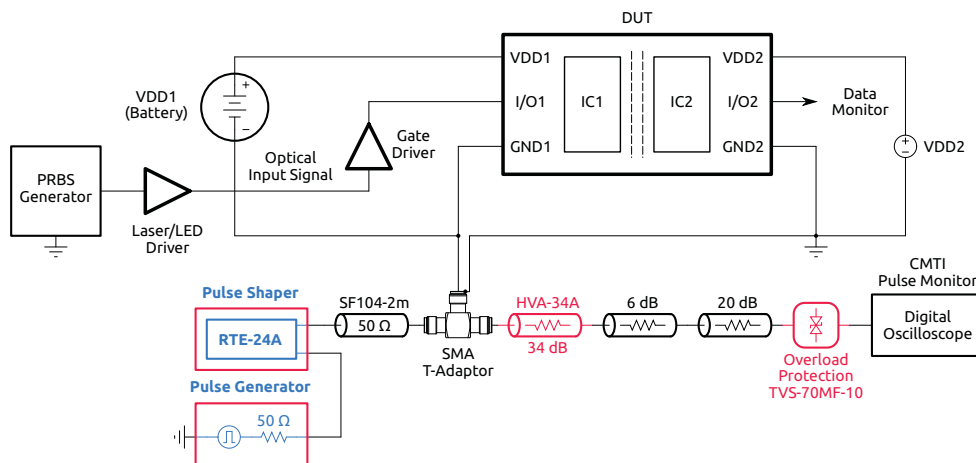

Figure 6: Dynamic terminated load measurement setup including pulse monitoring

Rise Time Extender RTE-24A

Advanced TLP/HMM/HBM Solutions

3 Specifications

Parameter	Symbol	Limit Values			Unit	Remarks
		Min.	Typ.	Max.		
Pulse voltage	$V_{IO,50\Omega}$	-3		+3	kV	into 50 Ω ¹⁾
Output pulse rise time	t_r	0.1		1200	ns	up to 24 customized rise times ²⁾
Nominal static rise time tolerance			5	10	%	
Pulse-to-pulse rise time variation				20	ps	depending on pulse generator
Digital control interface	-	USB 2.0			-	Industrial isolated and EMI/ESD protected USB 2.0 interface
AC line voltage range	V_{AC}	100		240	V	47-63 Hz, max. 1.8 A
Dimensions RTE-24A (W x H x D)	D	428 (482.6) x 132.5 x 485			mm ³	428 mm body, 482.6 mm rack flange
Weight RTE-24A	W		10		kg	excluding accessories
Pulse I/O connectors	SMA					

¹⁾The maximum open load output voltage could reach 6.0 kV according the pulse voltage setting. But in reality the output voltage is limited by the breakdown voltage of the SMA connector and the interconnection devices towards the DUT. The SMA connector interface must be cleaned and fixed tight. The pulse voltage setting must not exceed the interconnection limits. The RTE-24A should not operated with maximum voltage at open load condition.

²⁾In case the custom defined rise times are in the range 0 ns to 50 ns, the maximum number of installable rise times remains 24. If the value of one rise time is in the range >50 ns to 200 ns, the maximum number of rise times will be decreased by 3. In case one rise time is in the >200 ns to 1200 ns, the maximum number of rise times will be decreased by 6.

4 Ordering Information

Pos.	Description	Part No.
01	Rise Time Extender, including: <ul style="list-style-type: none"> • 1.5 m power line cable • 3 m USB control cable • 0.5 m SMA(m)/SMA(m) 50 Ohm front panel interconnection cable • Memory stick including software update and manuals 	RTE-24A

General

The product data contained in this data-sheet is exclusively intended for technically trained staff. You and your technical departments will have to evaluate the suitability of the product for the intended application and the completeness of the product data with respect to such application. Our products are solely intended to be commercially used internally and should not be sold to consumers. This data-sheet is describing the specifications of our products for which a warranty is being granted by HPPI GmbH. Any such warranty is granted exclusively pursuant the terms and conditions of the respective supply agreement. There will be no guarantee of any kind for the product and its specifications. For further information on technology, specific applications of our product, delivery terms, conditions and prices please contact HPPI:

High Power Pulse Instruments GmbH
 Stadlerstrasse 6A
 D-85540 Haar, Germany
 Phone : +49 (0)89 8780698 - 440
 Fax : +49 (0)89 8780698 - 444
 E-Mail : info@hppi.de

Due to technical requirements our products and/or their application may be harmful. For information please read carefully the manual or contact HPPI. Safety notes in the manual will inform you about possible risks that result from any foreseeable application of our products. Changes of this data-sheet are reserved.