

## TLP/VF-TLP/HMM/HBM PROBING SOLUTIONS

### PHD-3001A

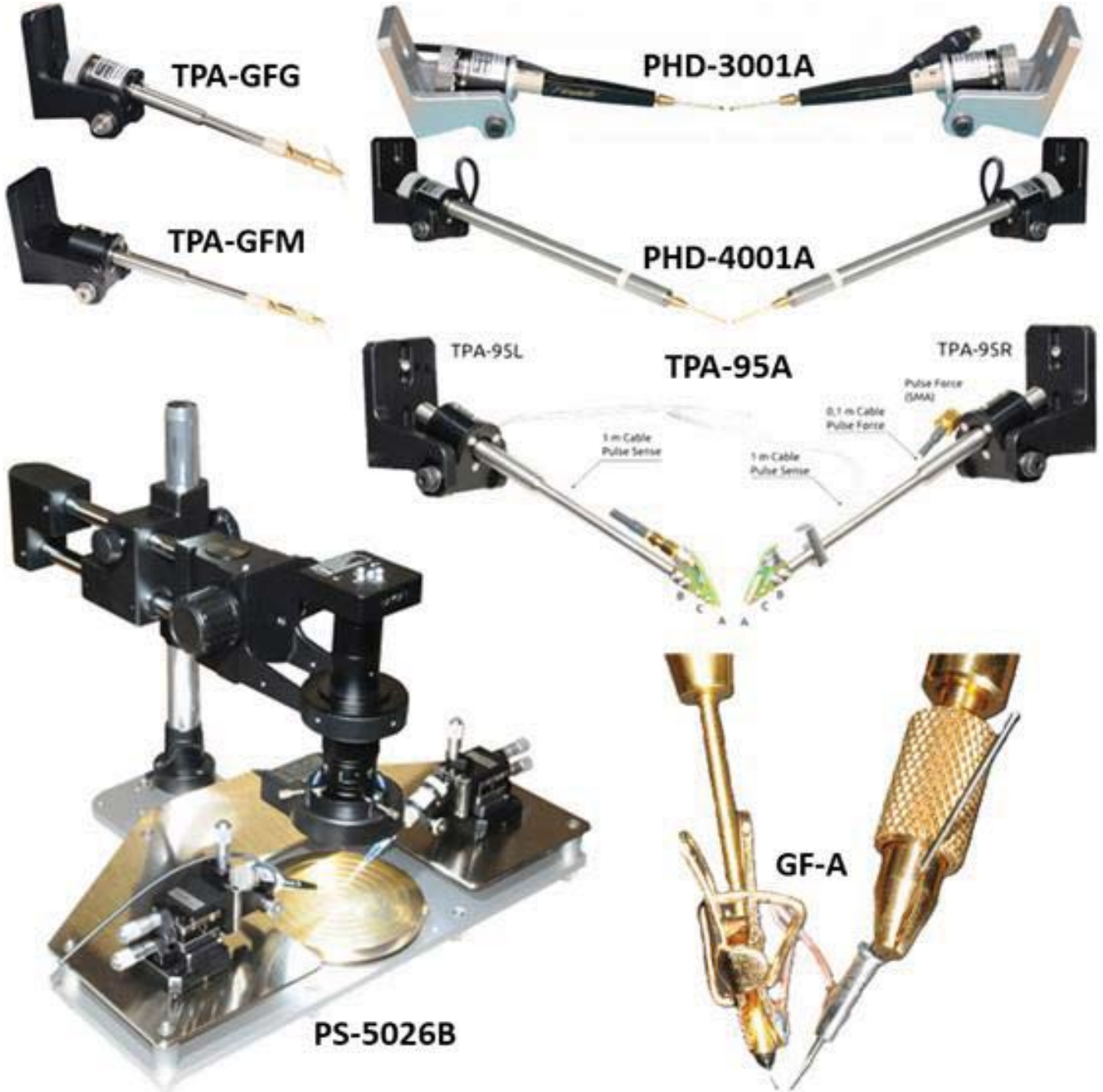

# Precision Picoprobe™ Micropositioner Kit PHD-3001A

Advanced TLP/HMM/HBM Solutions



## 1 Features

- Pulse force and pulse sense fixed pitch and flexible pitch RF probing solution for TLP/VF-TLP/HMM on-wafer measurements using Picoprobe™ Model 10
- High peak current capability 120 A (100 ns)
- Typical DC - 7 GHz bandwidth
- Isolated probe-head ground shield for high pulse sense common mode signal rejection
- Including fixed pitch replacement probe tip 50  $\Omega$ , right, 100  $\mu\text{m}$  pad pitch
- Including fixed pitch replacement probe tip 5 k $\Omega$ , left, 100  $\mu\text{m}$  pad pitch
- Including flexible pitch clamps plus 10-5k(0502)-125-W-1 and 10-50/30-125-W-1 replacement probe tips
- True coaxial high-resolution 80:1 rotary probe-head for accurate probe tip adjustment



Figure 1: PHD-3001A Picoprobe™ Precision Micropositioner Kit, customizable for various micropositioner

## 2 System Description

The Precision Picoprobe™ Micropositioner Kit PHD-3001A enables wafer-level TLP/VF-TLP/HMM measurements in a 4-wire (Kelvin) pulse-force and pulse-sense configuration for high measurement accuracy and high time resolution (Fig. 2). The measurement bandwidth of the probing system is DC - 7 GHz for detailed investigation of turn-on and snap-back characteristics of the device under test at high currents of 120 A. For high common mode rejection of the pulsed signals at high current levels the probe-head ground shield is isolated from the chuck ground.

Fig. 1 shows the photograph of the PHD-3001A-P1R pulse force assembly. A shaft extension can be mounted optionally as shown in Fig. 10 for increased positioning flexibility. All parts of the kit are listed in the part list. The standard kit is configured for the Suss PH110 micropositioner or similar. For all other micropositioner vendors interfaces are available on request.

For fixed pitch as well as flex pitch probing all required accessories are included with the kit.

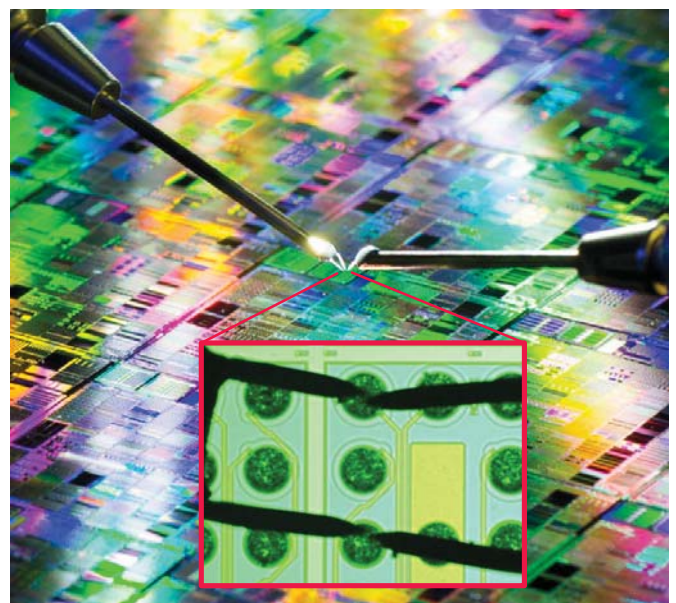

Figure 2: Application example<sup>1</sup>

<sup>1</sup>Image source: <https://www.emft.fraunhofer.de/en/applications/2-pin-test-system-electrical-testing.html>, ©Fraunhofer EMFT/Bernd Müller.

# Precision Picoprobe™ Micropositioner Kit PHD-3001A

Advanced TLP/HMM/HBM Solutions

## 2.1 Fixed-Pitch Probe Tips

Fig. 3 shows typical fixed pitch (200 μm) probetips for the model 10 probe tip holder.

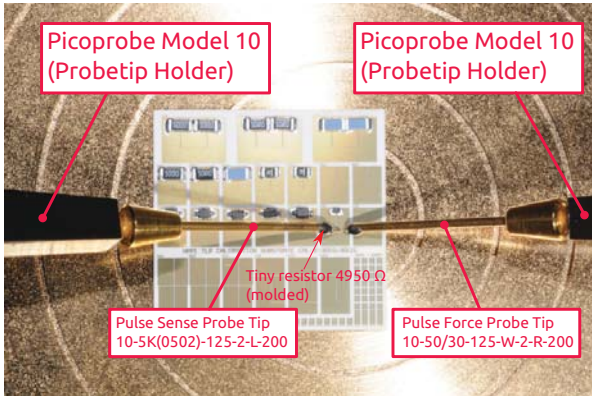

Figure 3: Fixed pitch picoprobes. Probing a reference device on the TLP calibration substrate.

Fig. 4 shows the detail view of Fig. 3 including the equivalent circuit of the GS-type (ground-signal) probe tips. On the left sided probe tip clearly the molded resistor can be identified. The mold compound is a little bit larger in comparison to the right sided 50 Ω probe tip without built-in resistor.



Figure 4: Fixed pitch picoprobes. Probing a reference device on the TLP calibration substrate. Detail view of Fig. 3 including equivalent circuit of the probe tips.

## 2.2 Flexible-Pitch Probe Tips

Sometimes the fixed pitch is a limitation in case of devices to be measured changes often and have different pad pitch and dimensions. For these cases the flexible pitch clamps and probes tips are included in the kit. The 10-50/30-125-W-1 (pulse force) and 10-5k(0502)-125-W-1 (pulse sense) probe tips have a center conductor/needle but no ground needle. The ground contact is made using a clamp, short flexible wire, nozzle for a 0.508 mm (20 mil) needle and a separate probe arm for the ground needle. Despite the ground con-

nection using a clamp with wire the pulse signal quality remains very good for rise times down to 200 ps.



Figure 5: Ground fixture GF-A clamped on the probe tips

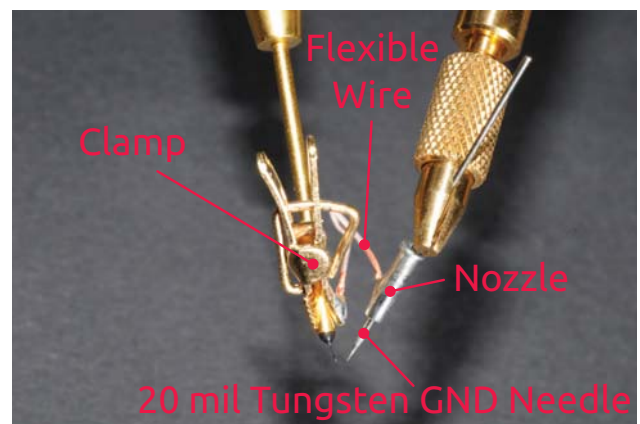

Figure 6: Ground fixture assembly GF-A: clamp, flexible wire and nozzle including 0.508 mm (20 mil) tungsten needle

Fig. 6 shows the ground fixture comprising the clamp, flexible wire and nozzle including 0.5 mm tungsten needle. The clamp needs to be fixed on the picoprobe tip. The tungsten needle shall be mounted on a separate DC probe arm including micropositioner (not supplied by HPPI).

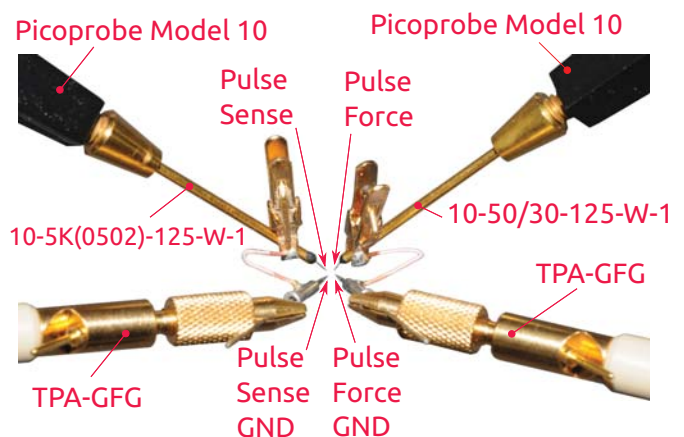

Figure 7: Flexible pitch setup using 10-50/30-125-W-1 (pulse force) and 10-5k(0502)-125-W-1 (pulse sense) replacement probe tips and GF-A flexible pitch ground fixture

Fig. 5 shows the clamp fixed on the probe tip. The final result of the assembly is shown in Fig. 7.

# Precision Picoprobe™ Micropositioner Kit PHD-3001A

Advanced TLP/HMM/HBM Solutions

## 3 Physical Dimensions

### 3.1 Standard Version for 200 mm Probe Stations

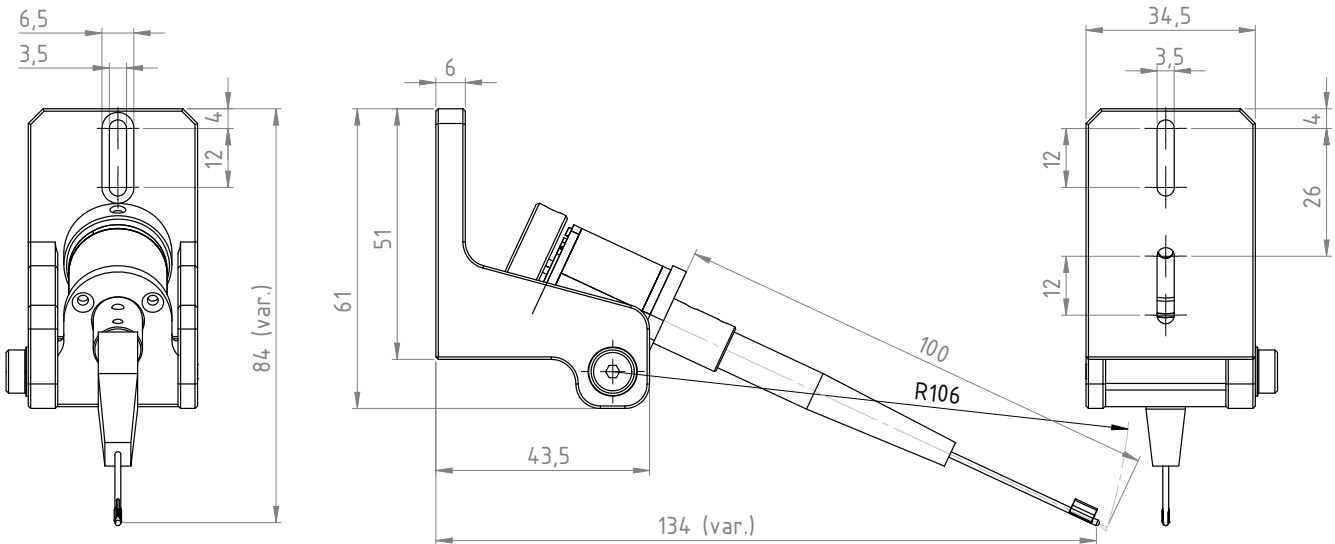

Figure 8: Dimensions of left sided probe assembly in [mm]. The right sided assembly has same dimensions.

### 3.2 Extended Version for 300 mm Probe Stations

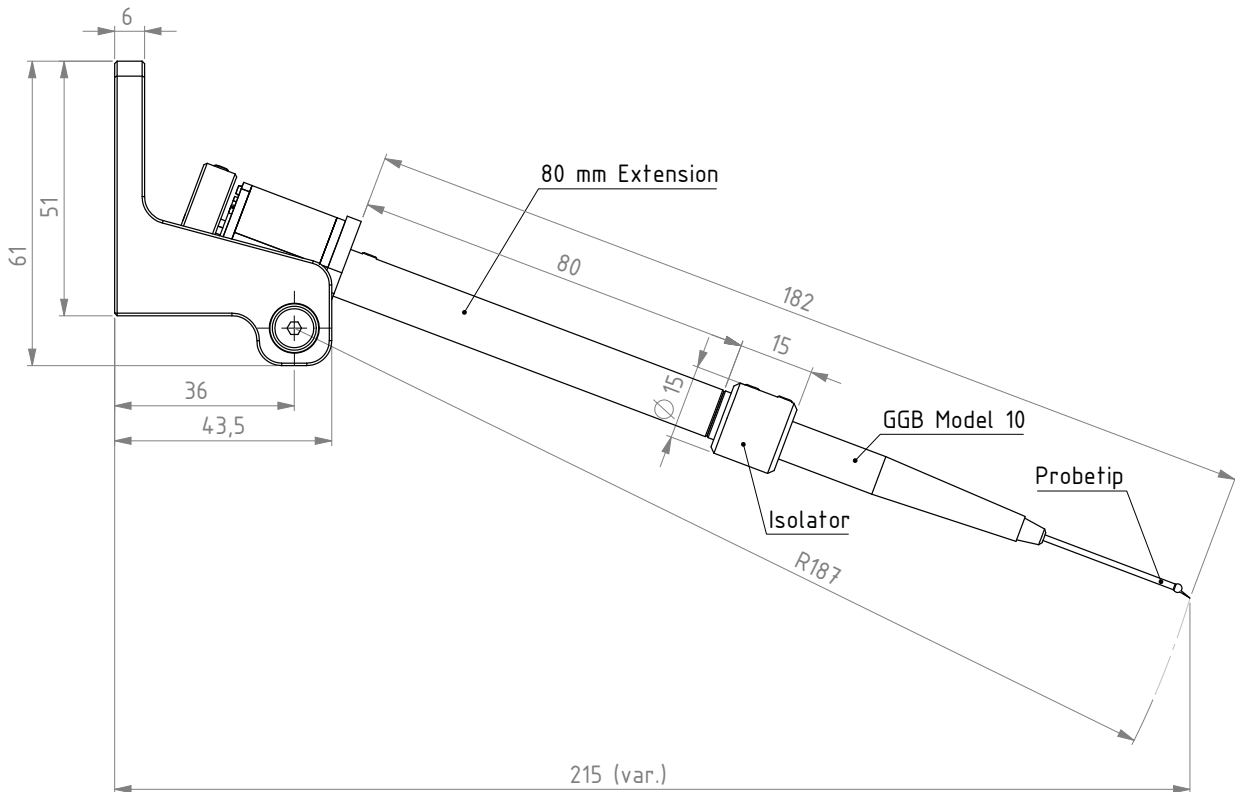

Figure 9: Dimensions of left sided probe assembly in [mm]. The right sided assembly has same dimensions.

# Precision Picoprobe™ Micropositioner Kit PHD-3001A

Advanced TLP/HMM/HBM Solutions



Figure 10: Photograph of shaft extension (PPM10\_H7)

## 4 List of Parts

A Precision Picoprobe™ Micropositioner Kit PHD-3001A consists typically of the following parts:

Qty.	Description	Part No.
1	Micromanipulator interface (right sided)	PHD-3001A-P1R
1	Micromanipulator interface (left sided)	PHD-3001A-P1L
2	Picoprobe™ Model 10 including SMA 50 Ω cables (1 m and 0.1 m length)	PHD-3001A-PM10
2	Shaft extension 80 mm	PPM10_H7
2	Fixed pitch replacement probe tip 50 Ω, right, 100 μm pad pitch	10-50/30-125-W-2-R-100
2	Fixed pitch replacement probe tip 5 kΩ, left, 100 μm pad pitch	10-5k(0502)-125-W-2-L-100
2	Flex pitch pulse force replacement probe tip 50 Ω	10-50/30-125-W-1
2	Flex pitch pulse sense replacement probe tip 5 kΩ	10-5k(0502)-125-W-1
1	GND fixture clamp set, 2 clamps, right- and left sided, including 2 tungsten needles	GF-A

## 5 Ordering Information

Pos.	Description	Part No.
01	Precision Picoprobe™ Micropositioner Kit	PHD-3001A

### General

The product data contained in this data-sheet is exclusively intended for technically trained staff. You and your technical departments will have to evaluate the suitability of the product for the intended application and the completeness of the product data with respect to such application. Our products are solely intended to be commercially used internally and should not be sold to consumers. This data-sheet is describing the specifications of our products for which a warranty is being granted by HPPI GmbH. Any such warranty is granted exclusively pursuant the terms and conditions of the respective supply agreement. There will be no guarantee of any kind for the product and its specifications. For further information on technology, specific applications of our product, delivery terms, conditions and prices please contact HPPI:

High Power Pulse Instruments GmbH  
 Stadlerstrasse 6A  
 D-85540 Haar, Germany  
 Phone : +49 (0)89 8780698 - 440  
 Fax : +49 (0)89 8780698 - 444  
 E-Mail : info@hppi.de

Due to technical requirements our products and/or their application may be harmful. For information please read carefully the manual or contact HPPI. Safety notes in the manual will inform you about possible risks that result from any foreseeable application of our products. Changes of this data-sheet are reserved.