

# ITL-101 UNIVERSAL POWER TRANSMITTER

## Features At A Glance

- Suitable for DC, power lines, inverters
- 1-, 2-, 3-, and multi-phase
- Isolated channels each phase (3000V)
- DC-50kHz, Option DC-100kHz
- Fast response output for process control
- Outputs:  $\pm 20\text{mA}$  /  $\pm 5\text{V}$  / 4-20mA  
for power, 3600 pulses / hour for energy
- 0.2% accuracy
- Wide voltage range 10V – 600V
- Wide current range 10mA – 20A  
Extendable to 3000A
- Multi-phase: two outputs for power
- 85 – 264V AC supply
- 24V or 48V DC supply



## Yields Correct Power for any Wave Form

The ITL-101 broad-band DC-50kHz Power Transmitters are available as single-phase, 2-phase (ARON), 3-phase and multi-phase versions (e.g. channel 1/2 in ARON, 0-20mA / 4-20mA output; channel 3 0-5V for DC-power output). In addition to the standard current- and voltage ranges special ranges for current 10mA-20mA and voltage, 10V-600V, can be supplied. 3000Vac channel – and channel to output isolation results in maximum freedom for input connections. The ITL-101 withstands fast common mode transients and can be used in frequency inverters and other electronically switched loads. Available options are DC-100kHz, non-standard voltage range, non-standard current range, 40ms response output for process control, energy output (3600 pulses per hour for full scale), bipolar output to measure recuperated power, and single- and three phase 0-100A current sensors.

### Typical applications of an ITL-101:

- DC measurements
- 50/60/400Hz power line
- Thyristor controlled loads
- Cycle skipping
- Inverters



## Specifications

Standard Voltage ranges $U_n$	ITL-101-1/3: 120V; 250V, working range: 0-150%, DC-50kHz
	ITL-101-2/4: 200V; 400V, working range: 0-150%, DC-50kHz
Standard Current ranges $I_n$	ITL-101-1/2/3/4: 1A; 2A; 5A; 10A; 20A; working range: 0-150%, DC-50kHz
Power ranges	ITL-101-1 : $U_n * I_n$ corresponds to 20mA
	ITL-101-2 : $2x U_n * I_n \cos 60^\circ$ corresponds to 20mA
	ITL-101-3 : $3x U_n * I_n$ corresponds to 20mA
	ITL-101-4 : $2x U_n * I_n \cos 60^\circ$ corresponds to 20mA
	ITL-101-4 : $1x U_n * I_n$ corresponds to 5Vdc
Power Accuracy	40-400Hz: 0.1% reading + 0.2% range (0.2 typical)
	0<PF<1; DC, 400-1000Hz: 0.3% reading + 0.2%
	range, 0.7<PF<1; 1kHz-10kHz: 1% typical
Output	0-20 mA, 0-5V ; standard. Max. burden 500Ω at 20mA.
	4-20mA Option, bipolar output, option
Overload continuous	Voltage: 1.5 x $U_n$ ; current: $I_n < 10A$ , 3 x $I_n$ ; $I_n = 20A$ , 1.5 x $I_n$
Overload 1 second	Voltage: 3 x $U_n$ ; current: $I_n < 10A$ , 5 x $I_n$ ; $I_n = 20A$ , 2 x $I_n$
Input-output isolation	3kV / 50Hz / 1 minute
Temp. Range/- Coefficient	-10°C to +50°C; 0.002% / deg. C
Supply	85-264VAC (50Hz/60Hz), 3VA; DC supply option
Case	Light gray. Polycarbo / ABS case, wall mounting (M4 x 15, 85 x 50mm) Support rail mounting (DIN EN 50022-35)
Size	H x W x D = 70 x 100 x 115mm; 400gr.
Selection Guide	ITL-101-1 Single phase transmitter, specify voltage and current
	ITL-101-2 2-phase transmitter (ARON), specify voltage / current
	ITL-101-3 3-phase transmitter, specify voltage and current
	ITL-101-4 2-phase transmitter (ARON), output 0-20mA; 1-phase
	Transmitter output 1, 0-5V, specify voltages and currents ARON for symmetrical 3-phase systems only
Options	Option 01: Frequency range DC-100kHz
	Option 02: Non-standard voltage range, specify
	Option 03: Non-standard current range, specify
	Option 04: 40ms response time for process control
	Option 05: Energy output, 3600 TTL-pulses per hour at full scale
	Option 06: Bipolar output 0-±20mA, 0-±5V
	Option 07: Single- and three phase current sensor 0-100Arms / 150A dc. Wire size 7x12mm, case 70x100x142mm (DIN rail mounting)
	Option 08: 4-20mA output
	Option 09: DC-Supply: Specify 9-18VDC, 18-36VDC, 36-72VDC
Ordering information	Specify type, nominal voltage and current, and options

**ITL101-1, single phase**

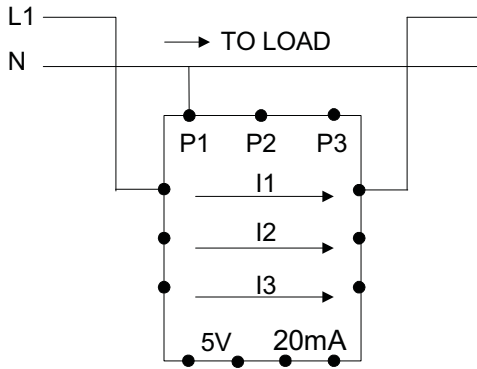

**ITL101-2, 2-phase ARON  
(for symmetrical systems only)**

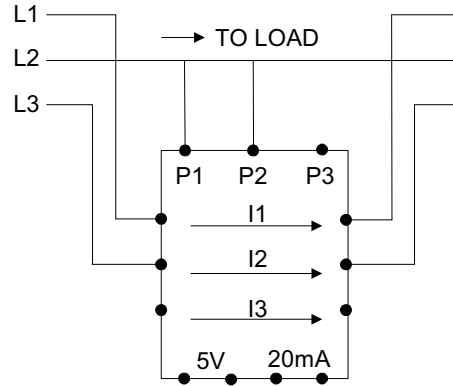

**ITL101-3, three phase**

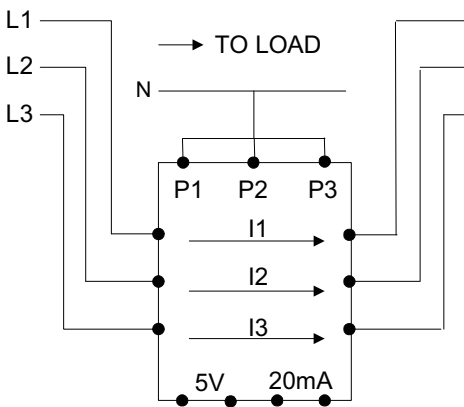

**ITL101-3, 3-phase using HALL SENSORS  
for currents up to 1000A**

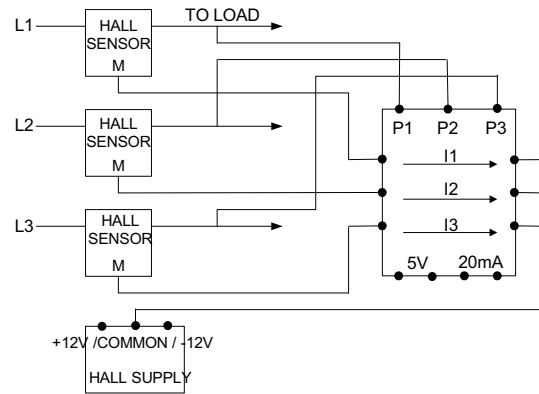

**ITL101-4, multi-phase**

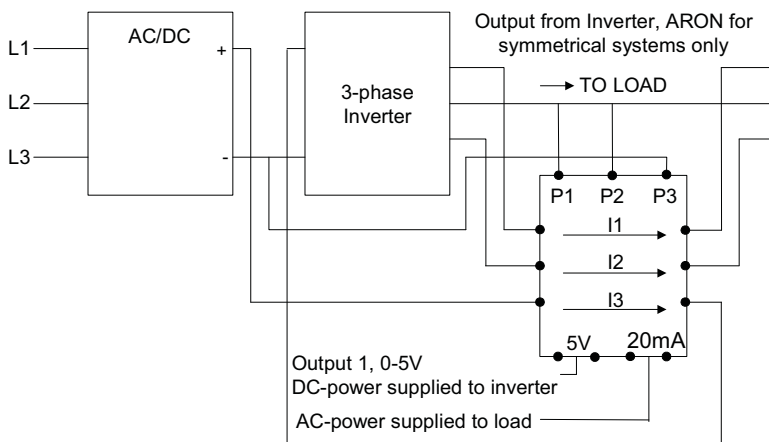

## Option 07: Connecting the Current Sensor Module to ITL-101

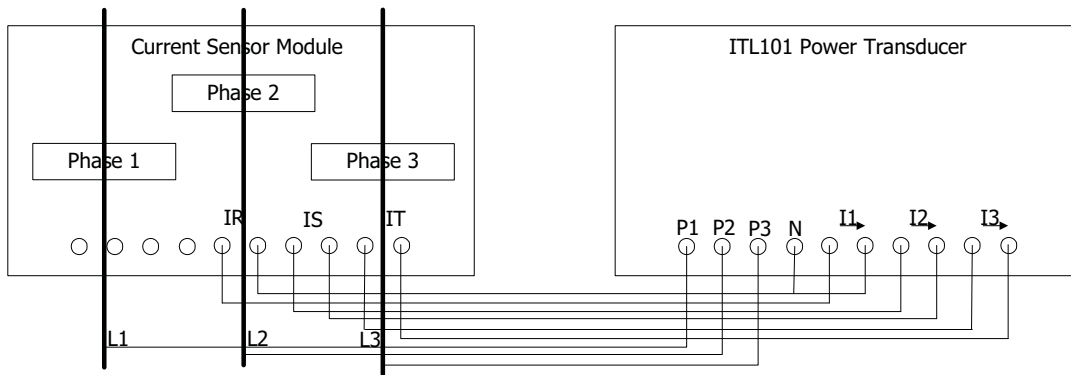

### Connection of one phase to ITL-101-3, using CT's and VT's

Select direction of current and voltage such that a positive output greater than 4mA results, power output range 4 to 20mA.

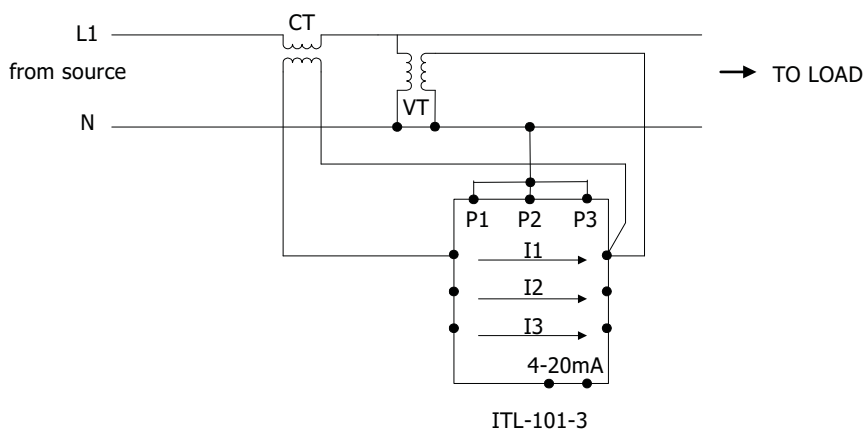

Distributed by:

Infratek AG  
Weingartenstrasse 6  
8707 Uetikon am See / Switzerland

Phone: +41 44 920 50 05  
Fax: +41 44 920 60 34  
Email: [info@infratek-ag.com](mailto:info@infratek-ag.com)  
Internet: [www.infratek-ag.com](http://www.infratek-ag.com)

