

Index

Feature: 2
FAQ 6
Appendix 1: Tearing Effect Signal 12
Appendix 2: Video Display Dialog 14
Appendix 3: Unable to Measure / Only Measure the LP Mode Signal / Too Many
Errors Solution: 16
Appendix 4: List of restored images 20

Feature:

Supported Models:

BF6264B	BF7264B	BF7264B+	BF7264 Pro
	•	•	•

BF7264B/B+/Pro has two USB holes at the front.

In addition to the host can continue to use the predecessor, BF6264B, functions, the newly added MIPI D-PHY analyzer function.

Specifications:

1. BF7264B/B+/Pro, 32Gb RAM, MIPI D-PHY probes

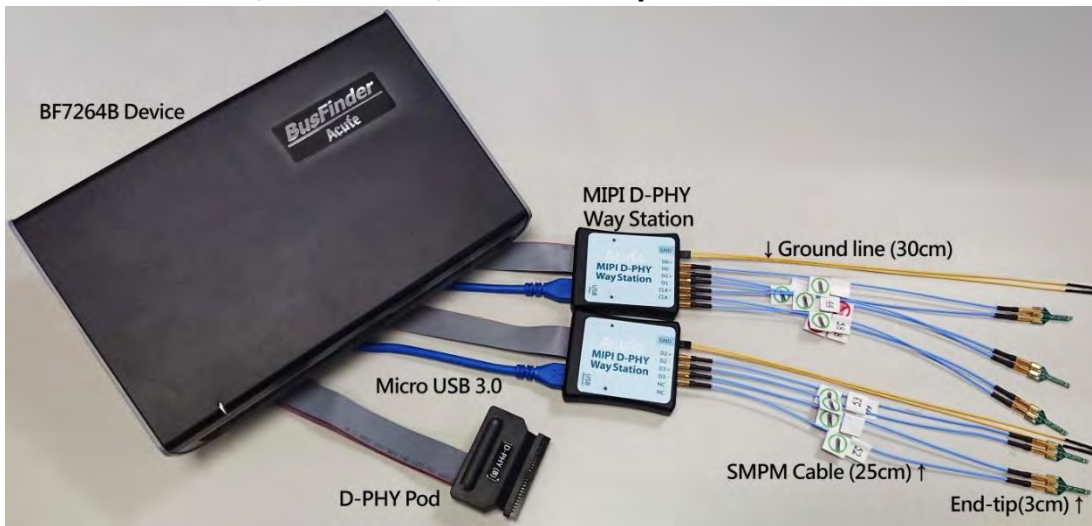

2. supports D-PHY V1.2

Up to 2.0Gbps per lane, 1 + 4 Lanes

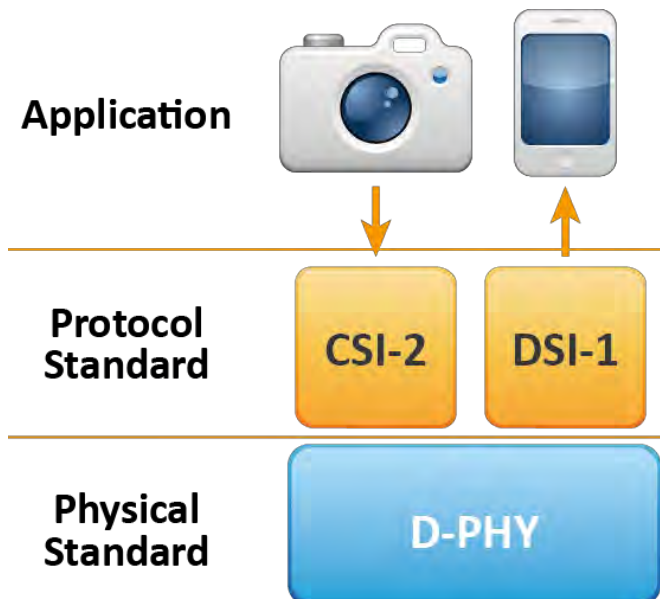

3. CSI-2 1.3 or DSI 1.3 protocol packets displayed as below with the DSI DCS

1.3 commands

Timestamp (bits.ms.us.ns.de)	Mode	VC	Data Type	DCS (A)	WC	Data (B)	Transaction Type	ECC (A)	CRC (B)
10.637.049.8...	LP (LPDT)	0	Generic Long Wri...		2	B0 03	Host proces...	00 (OK)	F84D (OK)
11.10.637.060.1...	LP (LPDT)	0	DCS Short WRITE...	53 (write control display)		24	Host proces...	08 (OK)	
12.10.637.066.5...	LP (LPDT)	0	DCS Short WRITE...	35 (set tear on)		00	Host proces...	2F (OK)	
13.10.637.083.3...	LP (LPDT)	0	Generic Long Wri...		2	B0 04	Host proces...	00 (OK)	8CF2 (OK)
14.10.637.105.0...	LP (LPDT)	0	Generic Long Wri...		3	EB 00 83	Host proces...	1A (OK)	AF71 (OK)
15.10.637.124.2...	LP (LPDT)	0	Generic Long Wri...		2	FB 00	Host proces...	00 (OK)	6818 (OK)
16.10.637.179.2...	LP (LPDT)	0	Generic Long Wri...		20	C8 01 00 04 FB FC CD 00...	Host proces...	19 (OK)	B76A (OK)
17.10.637.196.0...	LP (LPDT)	0	Generic Long Wri...		2	D6 01	Host proces...	00 (OK)	EADA (OK)
18.10.637.208.8...	LP (LPDT)	0	Generic Long Wri...		2	B0 03	Host proces...	00 (OK)	F84D (OK)
19.10.637.219.1...	LP (LPDT)	0	DCS Short WRITE...	11 (exit sleep mode)		00	Host proces...	36 (OK)	
20.10.637.205.4...	LP (LPDT)	0	DCS Short WRITE...	29 (set display on)		00	Host proces...	1C (OK)	
21.10.870.540.9...	LP (LPDT)	0	DCS Short WRITE...	51 (set display brightness)		FE	Host proces...	0D (OK)	
22.10.870.560.9...	LP (LPDT)	0	DCS READ, no par...	DA		00	Host proces...	1F (OK)	
23.10.870.562.6...	STA								
24.10.870.571.3...	LP (LPDT)	0	DCS Short READ R...			E1 00	Peripheral ...	27 (OK)	
25.10.870.573.4...	STA								
26.10.897.116.1...	HS	0	DCS Long Write/w...	2C (write memory_start)	2881	DC AC AA 9A 5A DC DE D2...	Host proces...	04 (OK)	
27.10.897.116.1...	HS	0	End of Transmiss...			0F 0F	Host proces...	01 (OK)	
28.10.897.134.6...	HS	0	DCS Long Write/w...	3C (write memory_continue)	2881	CA 1B CC EC 7A 5C 55 D2...	Host proces...	04 (OK)	
29.10.897.134.6...	HS	0	End of Transmiss...			0F 0F	Host proces...	01 (OK)	
30.10.897.153.2...	HS	0	DCS Long Write/w...	3C (write memory_continue)	2881	CA FD C2 CF F1 B0 3B 77...	Host proces...	04 (OK)	
31.10.897.153.2...	HS	0	End of Transmiss...			0F 0F	Host proces...	01 (OK)	
32.10.897.171.7...	HS	0	DCS Long Write/w...	3C (write memory_continue)	2881	3A 62 52 93 5E 8A 1B 77...	Host proces...	04 (OK)	
33.10.897.171.7...	HS	0	End of Transmiss...			0F 0F	Host proces...	01 (OK)	
34.10.897.190.2...	HS	0	DCS Long Write/w...	3C (write memory_continue)	2881	BA 15 C3 CF E5 B8 1E 6D...	Host proces...	04 (OK)	
35.10.897.190.2...	HS	0	End of Transmiss...			0F 0F	Host proces...	01 (OK)	

4. Use 32Gb RAM as the buffer to stream all D-PHY data into the SSD HD in order to record all data flow from Low Power Mode to High Speed Mode

Recordable data without streaming into the SSD HD:

Resolutions	Recordable frames	Note
1K (FHD 1080x1920)	~500	
2K (WQHD 1440x2560)	~280	
4K (UHD 2160x3840)	~120	8 lanes or 4 lanes with DSC compression
8K (4320x8192)	Not available	Not available

5. "Data Filter" filters unwanted video data to save memory
6. "Search" searches specific data
7. "ECC/CRC Packet" displays and counts ECC and CRC
8. Display DSI(CSI) image data including RGB, YCbCr, RAW format or compressed DSC packets, and count the Porch from raw data. For more information, please refer to Appendix 2.

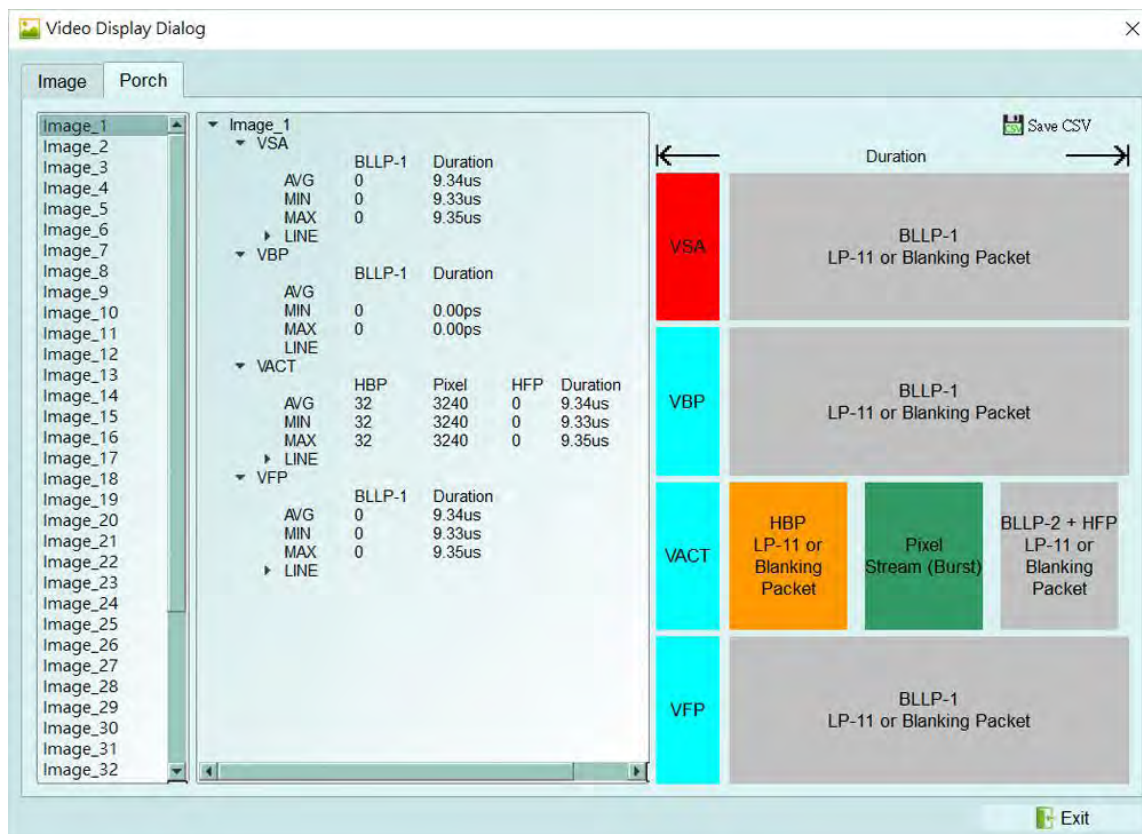
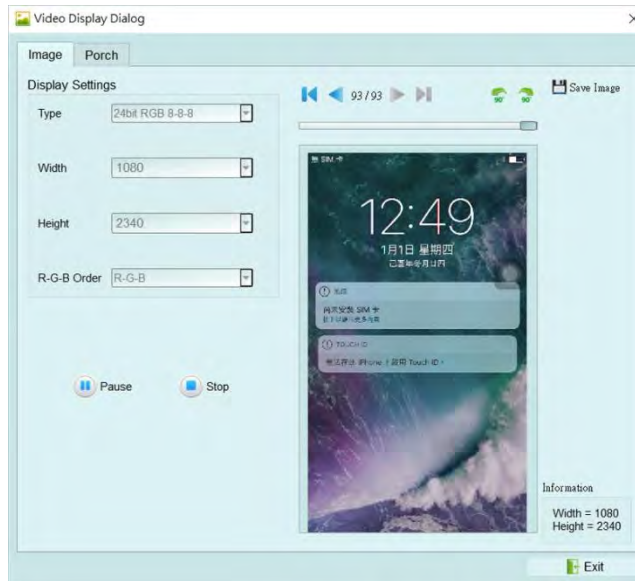

9. D-PHY command statistics include numbers of packets, individual command, different data length, and errors

Discription	Txns	Bytes	Statistics	Txns	Bytes
▶ Sampled Bus Error	2455		5E (set_CABC...	1	1
▶ DSI Error Report	0		55 (write_pow...	2	4
▼ DSI Bus			53 (write_cont...	1	1
VC 0	1044640	29739051	35 (set_tear_on)	1	1
VC 1	18	37	11 (exit_sleep_...	1	1
VC 2	245	493	29 (set_displa...	1	1
VC 3	499	628	51 (set_displa...	1	1
BTA	14		DA	1	1
Data Type	1044899	29740212	2C (write_me...	407	22385
DCS Command	521835	28694276	3C (write_me...	521293	28670727
Packet Count	1044900		20 (exit_invert...	3	129
			78	2	86
			1E	2	86
			60	2	44
			80	1	43

10. D-PHY command trigger

- Trigger parameters include commands and 32 bytes data in order to cover all short packets and most of non-video long packets.

Short Packet: 4-bytes Header

Long Packet: 4-bytes Header + 28-bytes Data

- CRC/ECC error trigger
- The Trigger-Out port is to trigger a DSO to capture waveforms

11. TE channel detect (Tearing Effect)

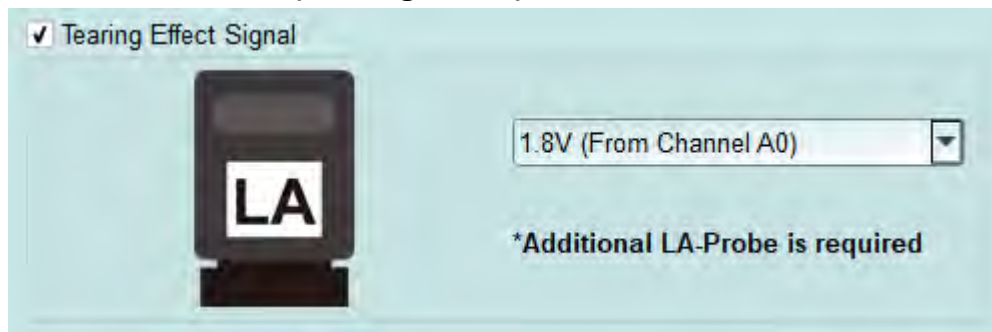

Detect the TE signal from the screen. Must purchase LA Probe to use this function.

Please refer to Appendix 1 for details.

FAQ

Q1. What MIPI DSI version is supported, any limitation for differential ports?

A: D-PHY V1.2, up to 2.0Gbps per lane, 1 + 4 lanes.

Q2. Is C-PHY supported?

A: No. Not now or in the future.

Q3. Is DSI-2 supported?

A: No, DSI-2 includes C-PHY signal which is not supported in this solution, the VDC-M image compression/decompression in DSI-2 is also not supported.

Q4. Will signal quality be affected while measuring?

A: Yes, that is why the end-tips and the SMPM coaxial cables are used to minimize the affections of signal quality.

Q5. Is Tx supported?

A: No.

Q6. How to connect the probes with the BusFinder?

A: The BusFinder can only use the Slot-B to connect the D-PHY probe. Please note that the two USB slots on the front of the BusFinder also need to be connected to the Way Station. The upper USB slot corresponds to the Top Way Station, and the lower USB slot corresponds to the Bottom Way Station. Then turn on the software, choose the D-PHY DSI/CSI , and pay attention to whether the two road station lights have red and green lights on.

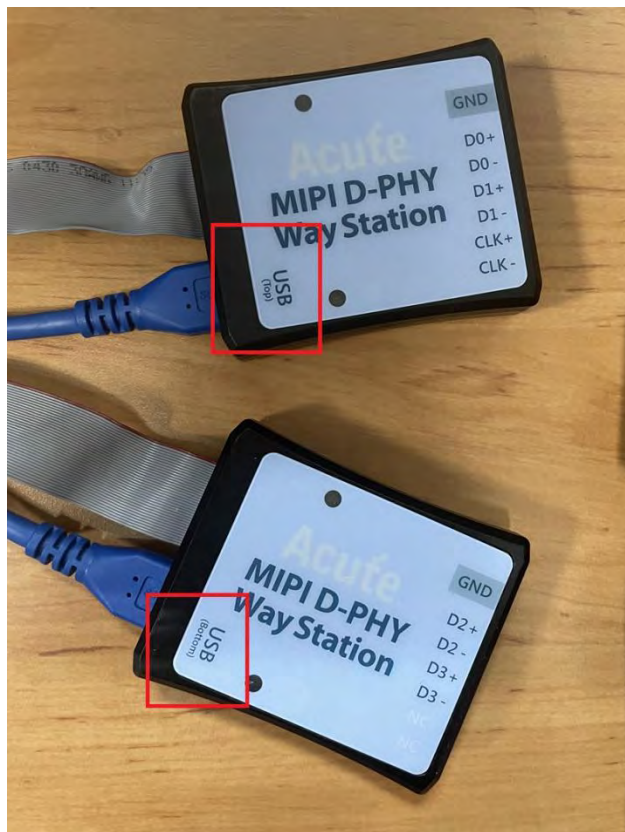
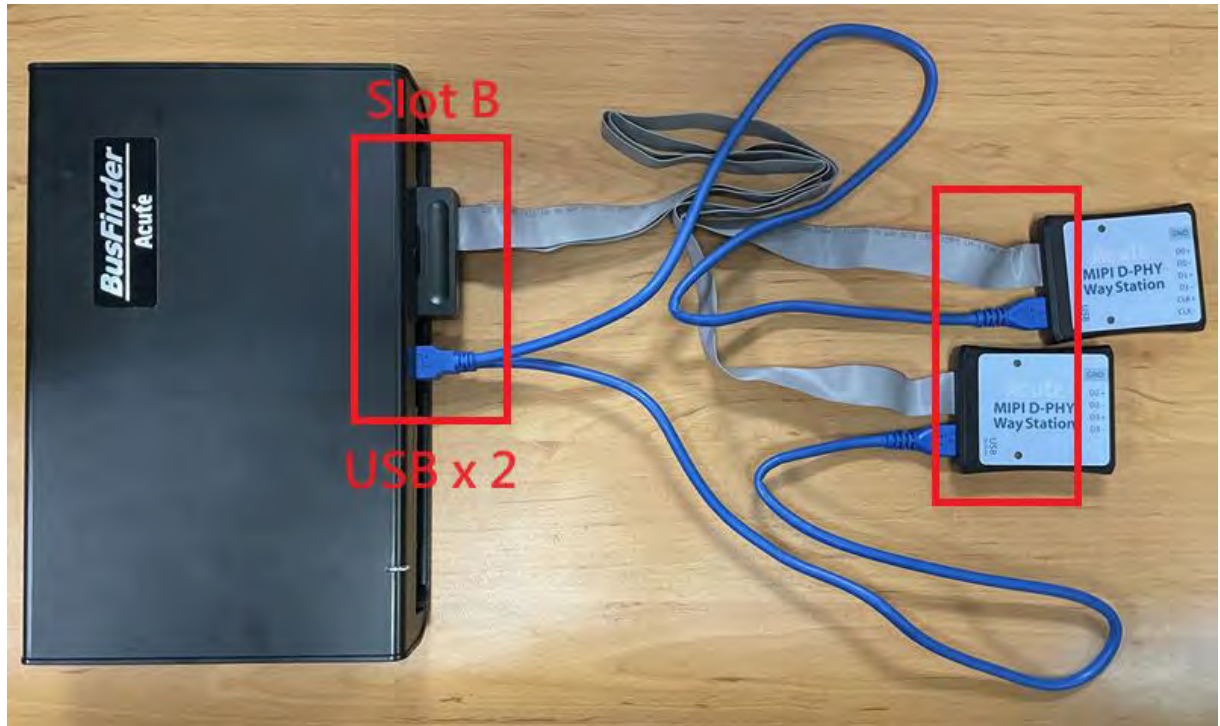

Q7. How to connect the probes with the DUT?

A : ① Weld the DUT:

FPC End-tip:



(Do not bend excessively to avoid internal open circuit of the FPC)

The welding line MUST be < 5mm. On the DUT, you are highly recommended to weld a 100Ω resistor and connect it to the End tip with a 3cm line.

Step 1: Connect the SMPM-SMPM cable to the End-tip first.

Step 2: Weld the End-tip to the DUT after Step 1.

※ End-tip R1/R2 resistor is 1kΩ/0402 which can be replaced if it breaks.

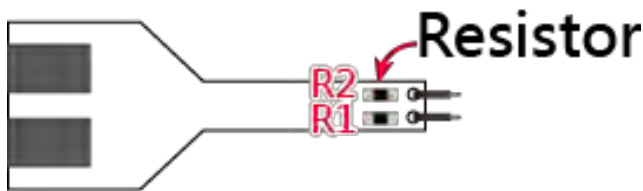

Solder R1, R2 to the corresponding resistor in the table, and C1 to the corresponding capacitor, and follow the PCB End-tip steps to complete the connection with the DUT

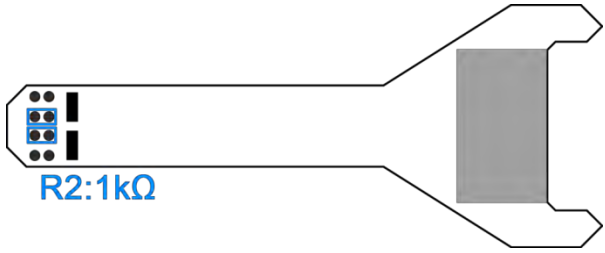
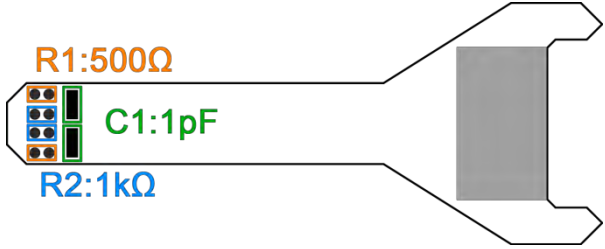
CLK	FPC End Tip
< 800Mbps	 <p>R2:1kΩ</p>
>= 800Mbps Standard	 <p>R1:500Ω C1:1pF R2:1kΩ</p>

② User-tip : User can design his own End-tip with 1kΩ resistor to connect the DUT, then

use the 50Ω impedance PCB trace to plug the SMPM connector.

③ Breakout: User can design his own EV board with the SMPM connector to connect Acute

MIPI D-PHY analyzer by breaking out the D-PHY host and device on the PCB board as the

chart below. R1/R2/R3 must be as close as possible by using 50Ω impedance.

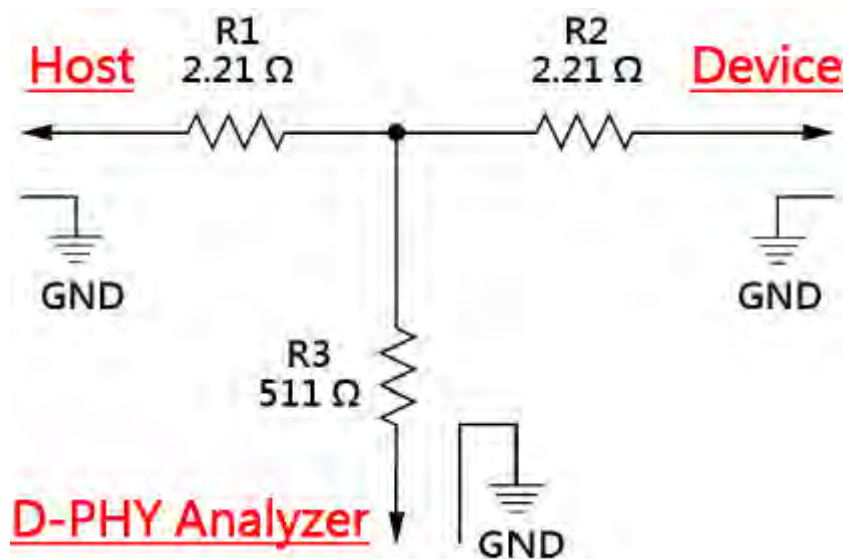

Q8. Use multimeter to check the short circuit.

After connections as below.

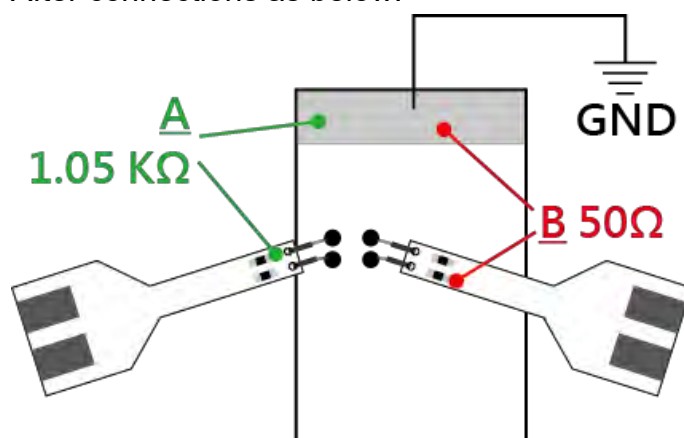

Check point **A**: End-tip resistor front to ground, **green line** ==> no sound from a multimeter.

Check point **B**: End-tip resistor back to ground, **red line** ==> sound from a multimeter, any short circuit?

A sound from a multimeter at point **B** is normal because it is low impedance of 50Ω at the resistor back. So, there is no short circuit if the resistor front of $1.05\text{K}\Omega$ without any sound.

Q9. How to connect the ground?

Two ways to connect the ground: End-tip or Way Station. (It is better connect the End-tip ground to the DUT ground to have the better quality; but the user may use to Way Station ground for convenience but to have lower quality signal.)

Since the device and the system under test still need to share the same ground, you can first connect the GND Port on the Way Station to the GND of the object under test. Both Way Stations must be connected.

Unless the signal quality is too poor or the interference is too large, and many errors occur after analysis, the best effect can be achieved by connecting each End-tip to ground, as shown in the red circle in the figure below.

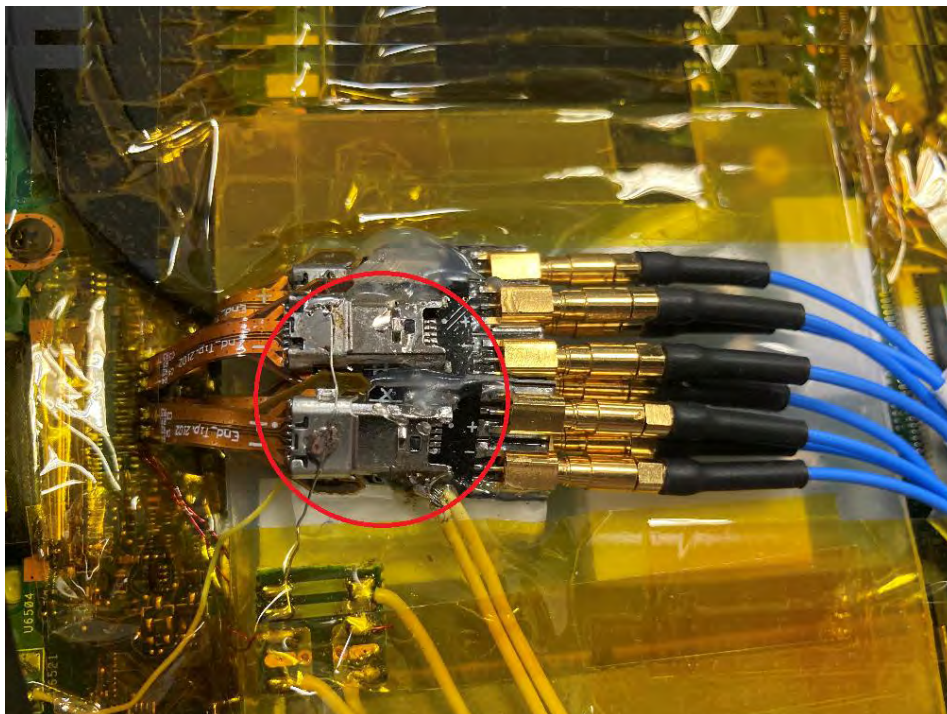

(Please solder the GND of the DUT directly to the connector at the end of the End-tip.)

Q10. Is DSI/CSI Data Type or Data trigger supported?

A: Yes, Data Type, DCS Command and Data trigger are supported by BF7264.

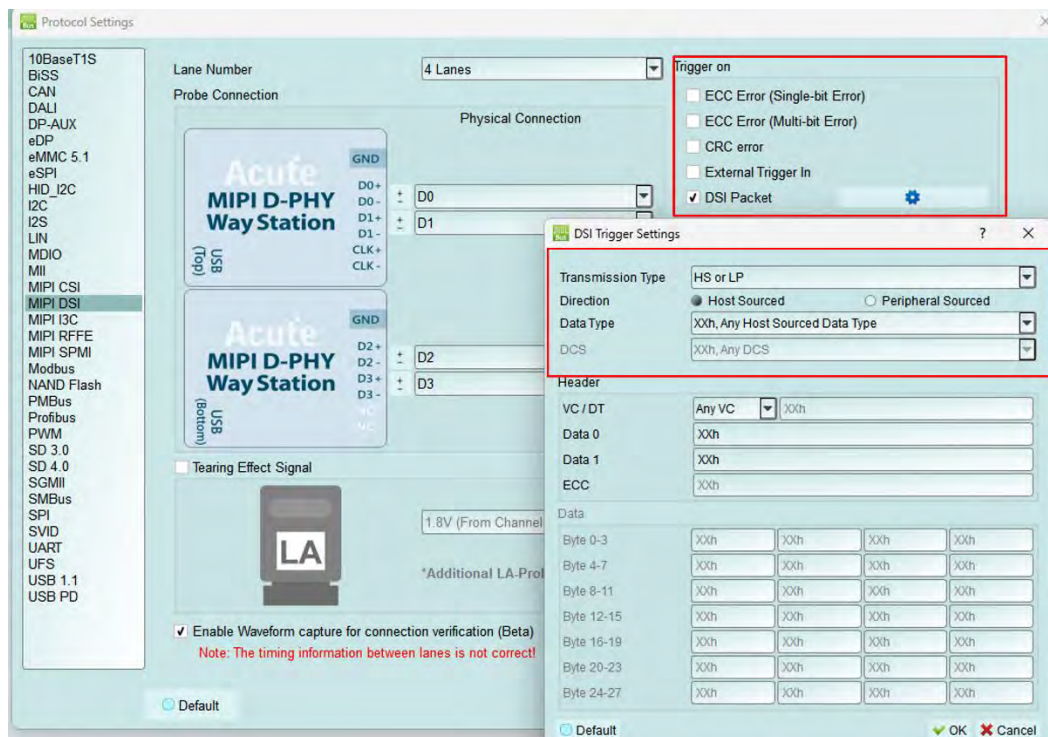

Q11. Is that possible to setup a HS, LP or DCS command as a start condition and then

capture data within specified time range?

A: Yes, after setup the HS, LP or DCS in the trigger settings as start condition, move to

Configuration and change the operation mode to Protocol Monitor mode, then you can specify the required capture time range.

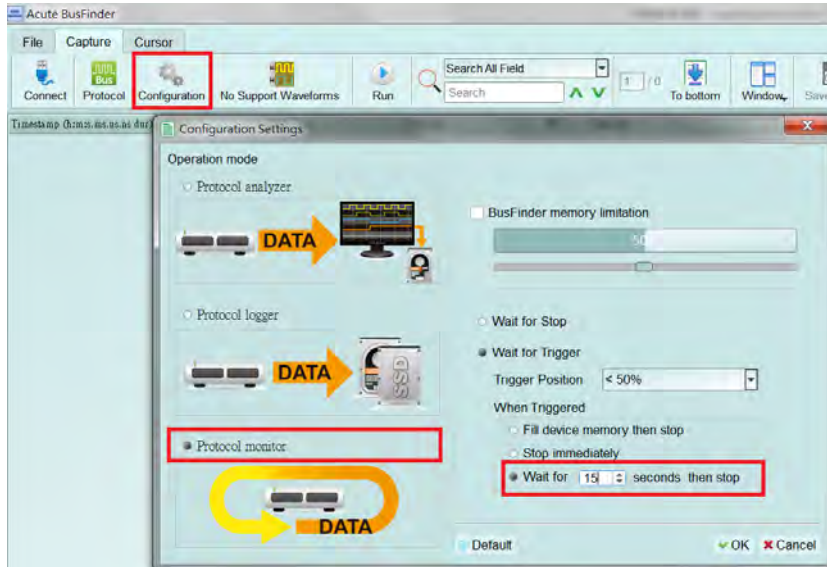

Appendix 1: Tearing Effect Signal

Tearing Effect (TE) pin signal detect.

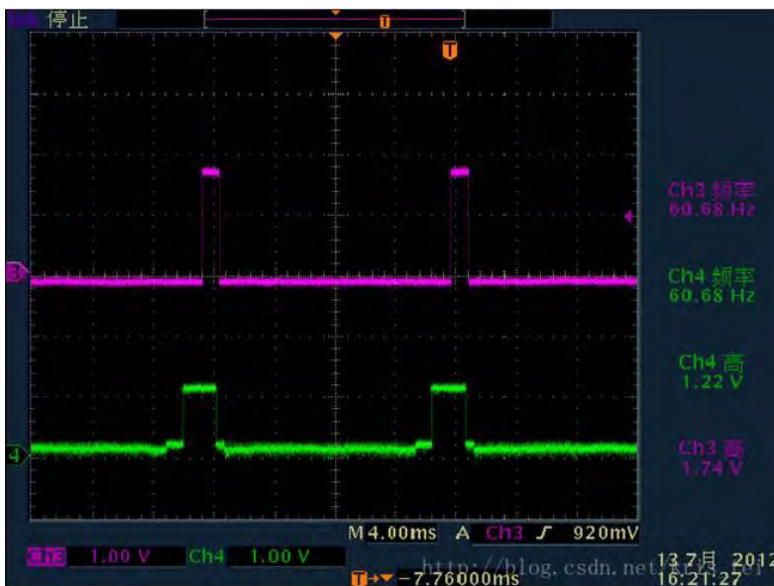

(Image Source: https://blog.csdn.net/kris_fei/article/details/77775553)

The TE pin is used by the display to inform the Host. At present, the data cannot be updated during the screen graphics drawing. If the screen is updated when TE = High, a horizontal break line will appear on the image. This function can clearly identify the failure to follow TE state operation instructions, reduce the time required to guess the problem and set up an oscilloscope to verify

The TE function requires the user to purchase an additional set of LA Probe to support it. The default input is from channel 0, which supports two operating voltage modes of

3.3V and 1.8V. The setting is as follows,

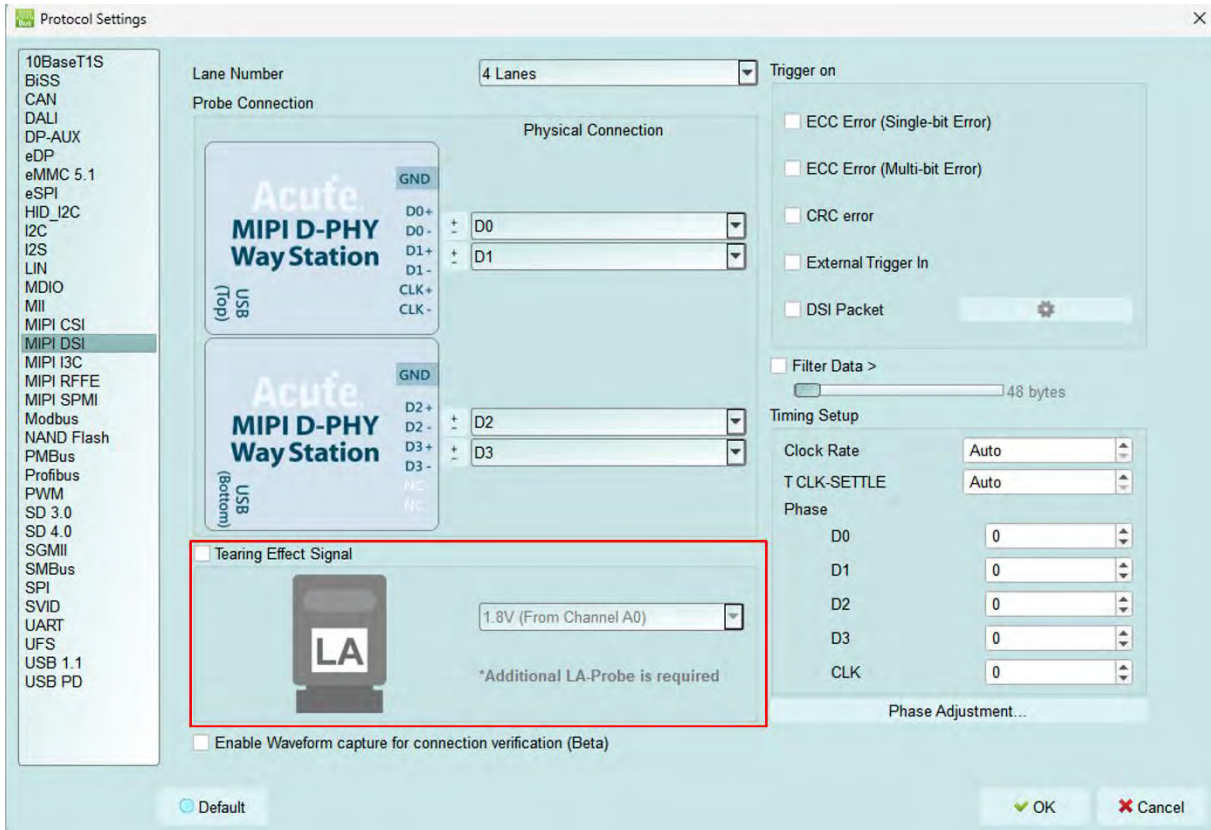

Result:

Time (ns)	Mode	VC	Data Type	DCS (h)	WC	Data (h)	Direction	ECC (h)	CRC (h)	Pkt. No.	IE	Format
4655	15:25:57.342...	HS	3	DCS Long Write/w...	CO	8385 08 FE B9 28 C9 D0 C6 C1...	Host -> Dev...	37 (Re...			1	Changing Incon
4656	15:25:57.342...	HS	1	Turn On Peripher...		C9 1A	Host -> Dev...	37 (Re...			1	Changing Incon
4657	15:25:57.342...	HS				1024 07 F8 DB F9 70 10 7C F7...	Host -> Dev...	F9 (Er...			1	Changing Incon
4658	15:25:57.343...	HS	0	End of Transmiss...		46 1E	Host -> Dev...	3A (Re...			1	Changing Incon
4659	15:25:57.343...	HS				1024 63 B8 21 B9 F0 42 60 B3...	Host -> Dev...	B9 (Er...			1	Changing Incon
4660	15:25:57.343...	HS	0	Sync Event, V Sy...		11 A6	Host -> Dev...	3A (Re...			1	Changing Incon
4661	15:25:57.343...	HS				1024 59 82 10 F8 E4 01 D1 39...	Host -> Dev...	F8 (Er...			1	Changing Incon
4662	15:25:57.343...	HS	1	DCS Short WRITE...	3C (write memory...	21	Host -> Dev...	0F (Re...			1	Changing Incon
4663	15:25:57.343...	HS				1024 36 34 18 B8 B8 40 80 B9...	Host -> Dev...	B8 (Er...			1	Changing Incon
4664	15:25:57.344...	HS	0	Generic Long Wri...		33932 1C 1F 64 B7 8D 18 38 39...	Host -> Dev...	39 (Re...			1	Changing Incon
4665	15:25:57.344...	HS				1024 56 B8 AC 79 08 C9 22 87...	Host -> Dev...	79 (Er...			1	Changing Incon
4666	15:25:57.345...	HS	2	Generic READ, no...		64 80	Host -> Dev...	0F (Re...			1	Changing Incon
4667	15:25:57.345...	HS				1024 83 63 44 B8 25 B6 4C F9...	Host -> Dev...	B8 (Er...			1	Changing Incon
4668	15:25:57.347...	HS	0	Sync Event, H Sy...		71 4C	Host -> Dev...	16 (Re...			1	Changing Incon
4669	15:25:57.347...	HS				1024 D9 9C 30 B8 58 B3 F4 B6...	Host -> Dev...	B8 (Er...			1	Changing Incon
4670	15:25:57.350...	HS	1	Packed Pixel Str...		19580 C8 78 3C F6 A4 9E 76 38...	Host -> Dev...	38 (Re...			1	Changing Incon
4671	15:25:57.350...	HS				1024 6C 35 3A B8 BC 4E 50 F5...	Host -> Dev...	B8 (Er...			1	Changing Incon
4672	15:25:57.350...	HS	3	Packed Pixel Str...		36924 A4 39 39 C2 A4 58 58 78...	Host -> Dev...	34 (Re...			1	Changing Incon
4673	15:25:57.350...	HS				1024 E4 E1 51 EA 2B 8C 14 B7...	Host -> Dev...	EA (Er...			1	Changing Incon
4674	15:25:57.353...	HS	2	Generic READ, 1 ...		80 16	Host -> Dev...	3A (Re...			1	Changing Incon
4675	15:25:57.353...	HS				1024 82 F9 62 7C 2B 8C E1 B5...	Host -> Dev...	7C (Er...			1	Changing Incon
4676	15:25:57.353...	HS	0	Picture Paramete...		4351 10 FF 4C F4 FF FF 00...	Host -> Dev...	13 (Re...			2	Changing Incon
4677	15:25:57.353...	HS				1024 80 8C 11 B4 20 70 5A B5...	Host -> Dev...	B4 (Er...			1	Changing Incon
4678	15:25:57.354...	HS	1	Packed Pixel Str...		27964 B8 64 0F 98 1C 98 98 78...	Host -> Dev...	34 (Re...			1	Changing Incon
4679	15:25:57.354...	HS				1024 64 60 88 B7 FB 7C 60 BA...	Host -> Dev...	B7 (Er...			1	Changing Incon
4680	15:25:57.354...	HS	1	Packed Pixel Str...		62750 B7 CB 3F 26 FF A5 9F 00...	Host -> Dev...	1D (Re...			1	Changing Incon
4681	15:25:57.354...	HS				4 68 6F 3A 34	Host -> Dev...	39 (Re...			2	Changing Incon
4682	15:25:57.354...	HS	2	Shut Down Periph...		75 D1	Host -> Dev...	39 (Re...			1	Changing Incon
4683	15:25:57.354...	HS				1024 EC 94 57 D1 E4 05 3A 93...	Host -> Dev...	D1 (Er...			1	Changing Incon
4684	15:25:57.356...	HS	1	Packed Pixel Str...		17842 F9 7D D9 48 FD D4 43 00...	Host -> Dev...	00 (Re...			1	Changing Incon
4685	15:25:57.356...	HS				1024 BA 50 9E 10 E4 12 AD 67...	Host -> Dev...	1A (Re...			1	Changing Incon
4686	15:25:57.356...	HS	3	Generic READ, 2 ...		E8 83	Host -> Dev...	1A (Re...			1	Changing Incon
4687	15:25:57.356...	HS				1024 B8 9C 7A 10 58 B8 E3 58...	Host -> Dev...	1A (Re...			1	Changing Incon
4688	15:25:57.357...	HS	2	Picture Paramete...		23429 4F 48 8C 58 CA 45 5E 70...	Host -> Dev...	1A (Re...			1	Changing Incon
4689	15:25:57.357...	HS				1024 2B 8C 29 B3 35 24 B1 76...	Host -> Dev...	B3 (Er...			1	Changing Incon
4690	15:25:57.357...	HS	3	Packed Pixel Str...		32748 BC B4 B8 1B DC 04 B8 59...	Host -> Dev...	3A (Re...			1	Changing Incon
4691	15:25:57.357...	HS	1	Null Packet, no ...		12039 C9 C5 9C F4 59 C8 42 F7...	Host -> Dev...	1A (Re...			1	Changing Incon

Appendix 2: Video Display Dialog

Click Window-> Video Display Dialog to open the video display dialog,

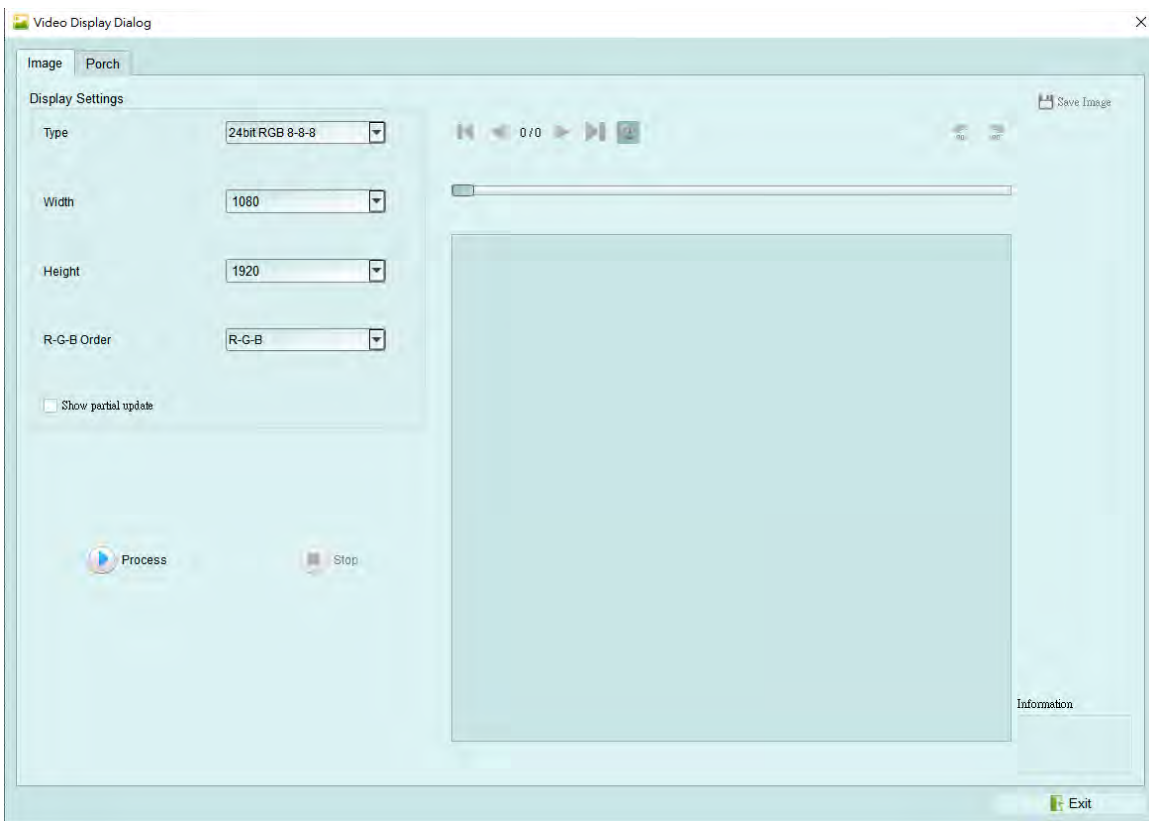
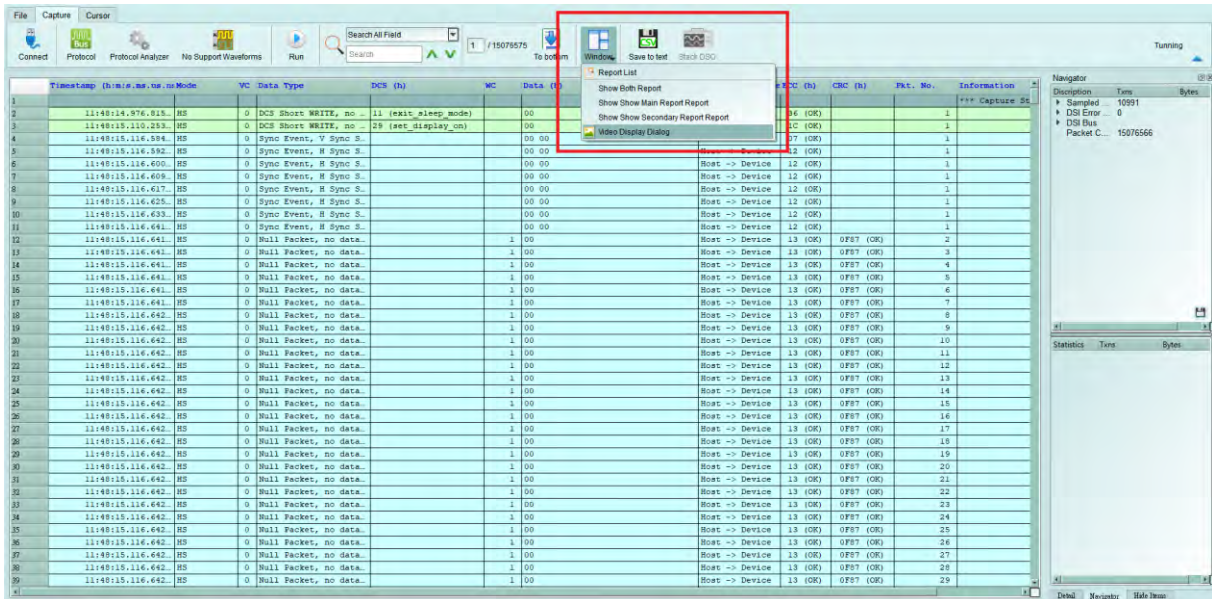

Please set the DSI, CSI format, resolution, RGB order, and then press Process to restore the image. Partial analysis function is also provided. If the DUT only updates part of the screen, this option can be checked to display part of the updated content.

Example:

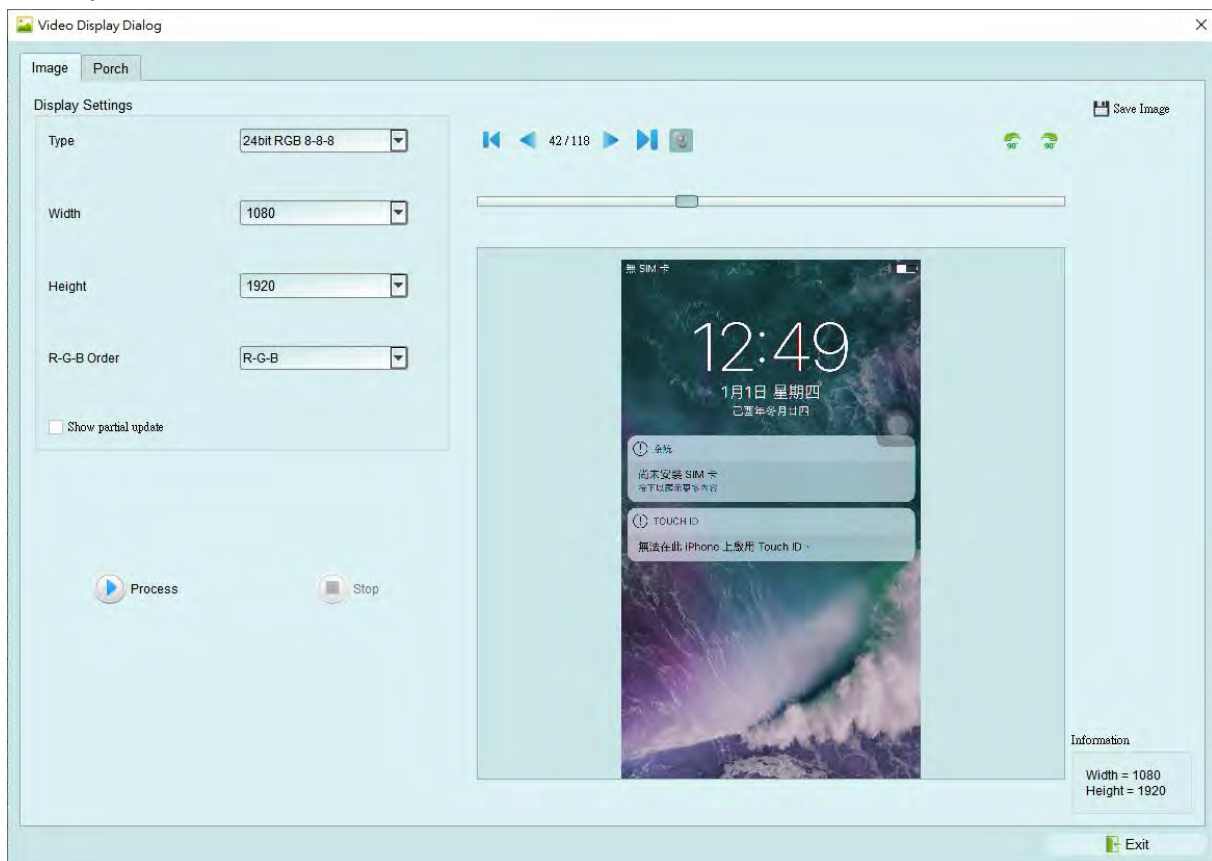

It also provides a linkage function with the data in the main report area, making it easy to find the location of the image data.

Save Image can output the restored image as .jpg / .bmp / .bin.

If DSI transmits image data in Video mode, there is also a Porch function that can count the format sent by each image. Ex: VSA, VBP, VFP, HBP, HFP, image.

If you choose TYPE-DSC restore, please select DSC Command mode use DCS Command.

If you use V-Sync / H-Sync format, please select DSC Video mode. Specify the PPS file (format .txt) to restore. PPS will also be replaced with the Picture Parameter Set (0A) command.

Appendix 3: Unable to Measure / Only Measure the LP Mode Signal / Too Many Errors Solution:

Step 1: Please check whether the 2 USBs between the probe and the BudFinder are not connected well.

- Unplug the USB of the host device and that of the WayStation, then plug it back in.

Step 2: Please check if the Lane/CLK wire is within 5mm of the regulation, and make sure that each end-tip is connected to Gnd.

Step 3: Turn on the waveform viewing function and send out the HS signal to make sure the connection is correct.

Step 3.1: Enable Waveform capture for connection verification (Beta)

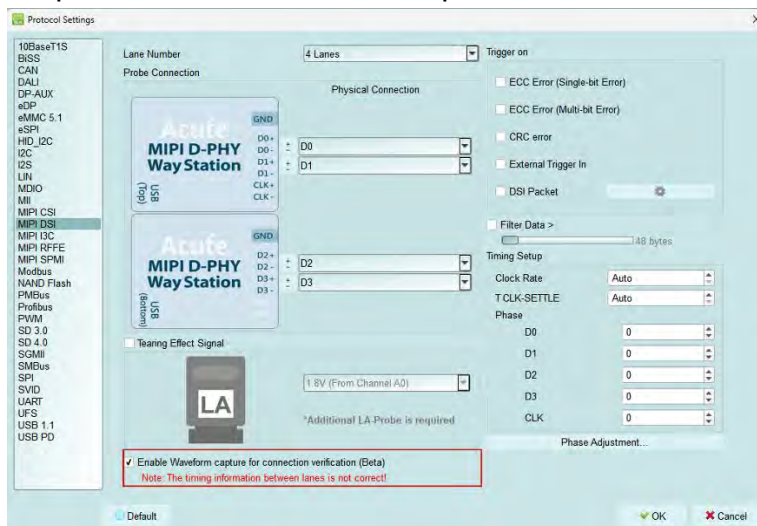

Step 3.2: Switch the “Configuration Settings”. Use the “Protocol Monitor mode” and limit the memory to 1-3%. If the problem is solved, switch back to “Protocol Analyzer mode”

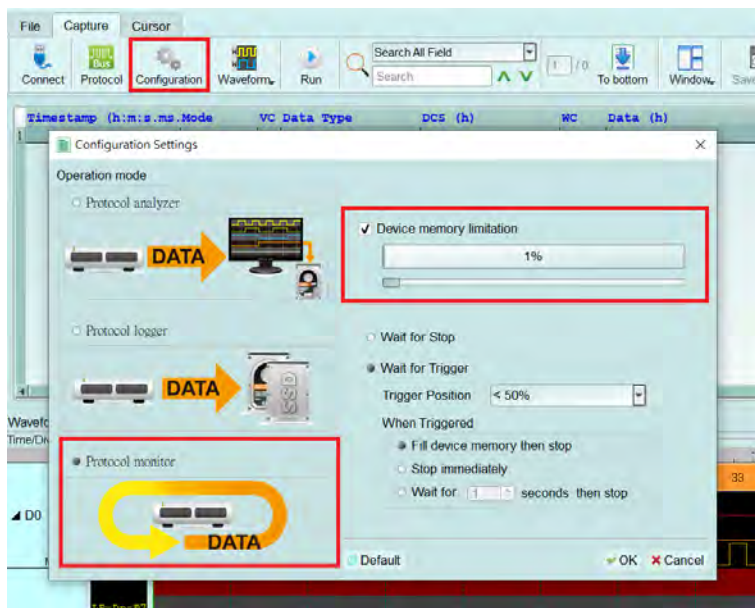

Step 3.3: Show Waveforms

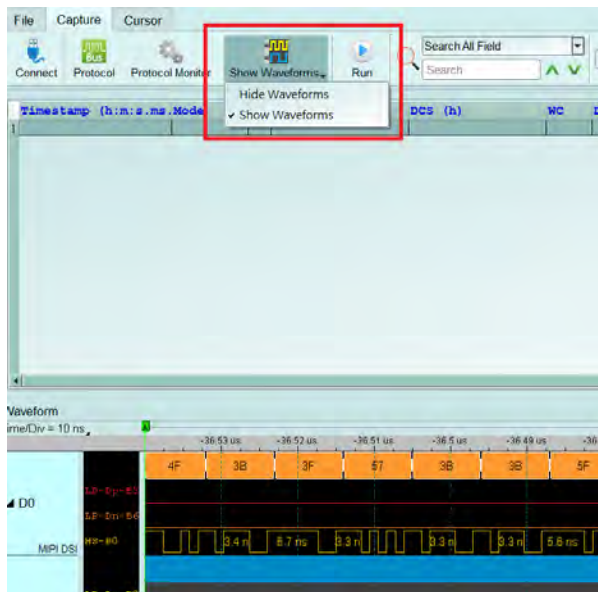

Step 3.4: Capture the waveform

Step 3.5: Analyze whether there is an HS signal. Before the red arrow is the LP signal, and after the waveform is the HS signal. (At the position of the red arrow, the LP signal of P/N becomes low, and HS starts to have signal.) Please find a similar position and zoom in to view the waveform. If the collection is repeated many times, the intersection of LP and HS still cannot be found. The Lane/CLK may be disconnected. Please refer to the FAQ 7.

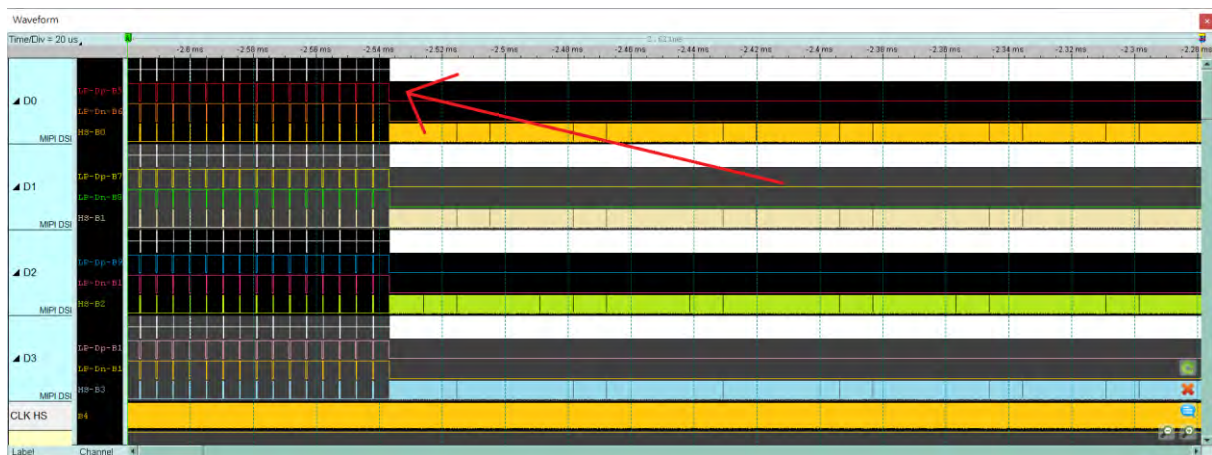

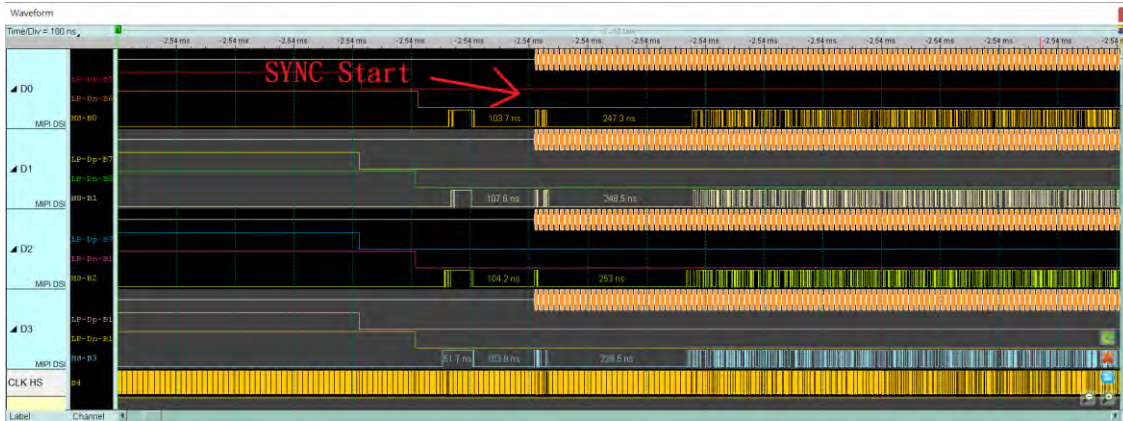

Step 3.6: Confirm whether the CLK Duty is 50:50, and check the width of each edge of Lane 0-3 behind HS SYNC. Normally, it is the width of half a CLK cycle or multiple. If it is abnormal, please check whether the bonding wire meets the requirements again. If it meets the regulations, there will still be noise or CLK Duty problems, please continue to shorten the wire length, and need to use the GND closest to the signal.

Ex: Bad CLK duty, 65:35, 1.4ns:0.8ns

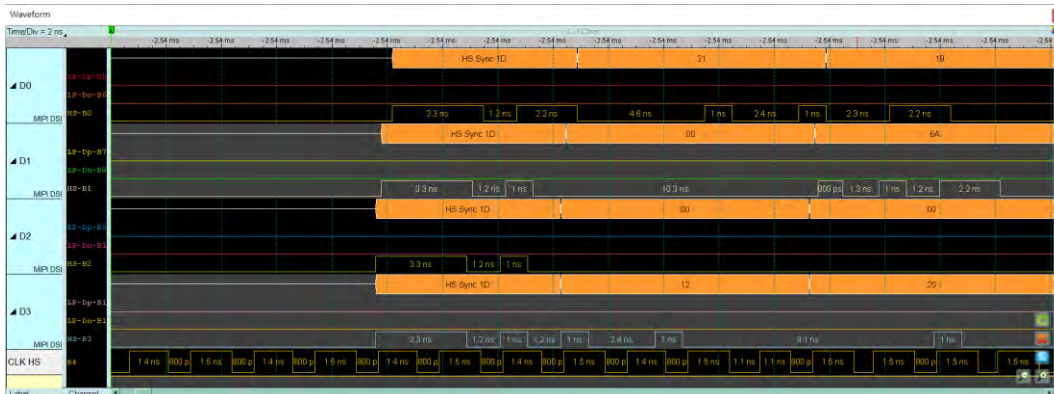

Ex: The width of high pulse in Lane 0, Lane 3 is not the width of half CLK cycle
 Half CLK cycle = $(1.4 + 0.8) / 2 = 1.1$ (ns)

Under normal conditions, the width is about 1.1ns or multiple.

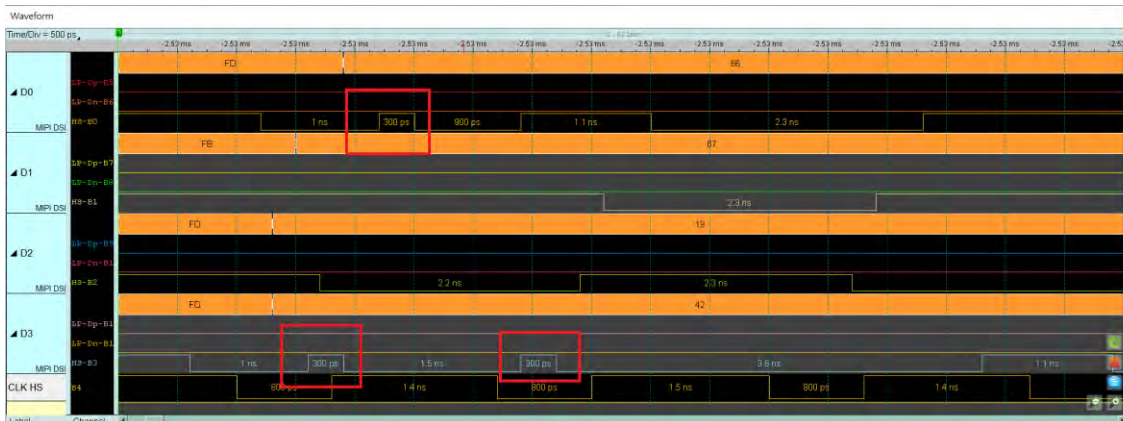

Appendix 4: List of restored images

1. Video mode - 1125 * 2436

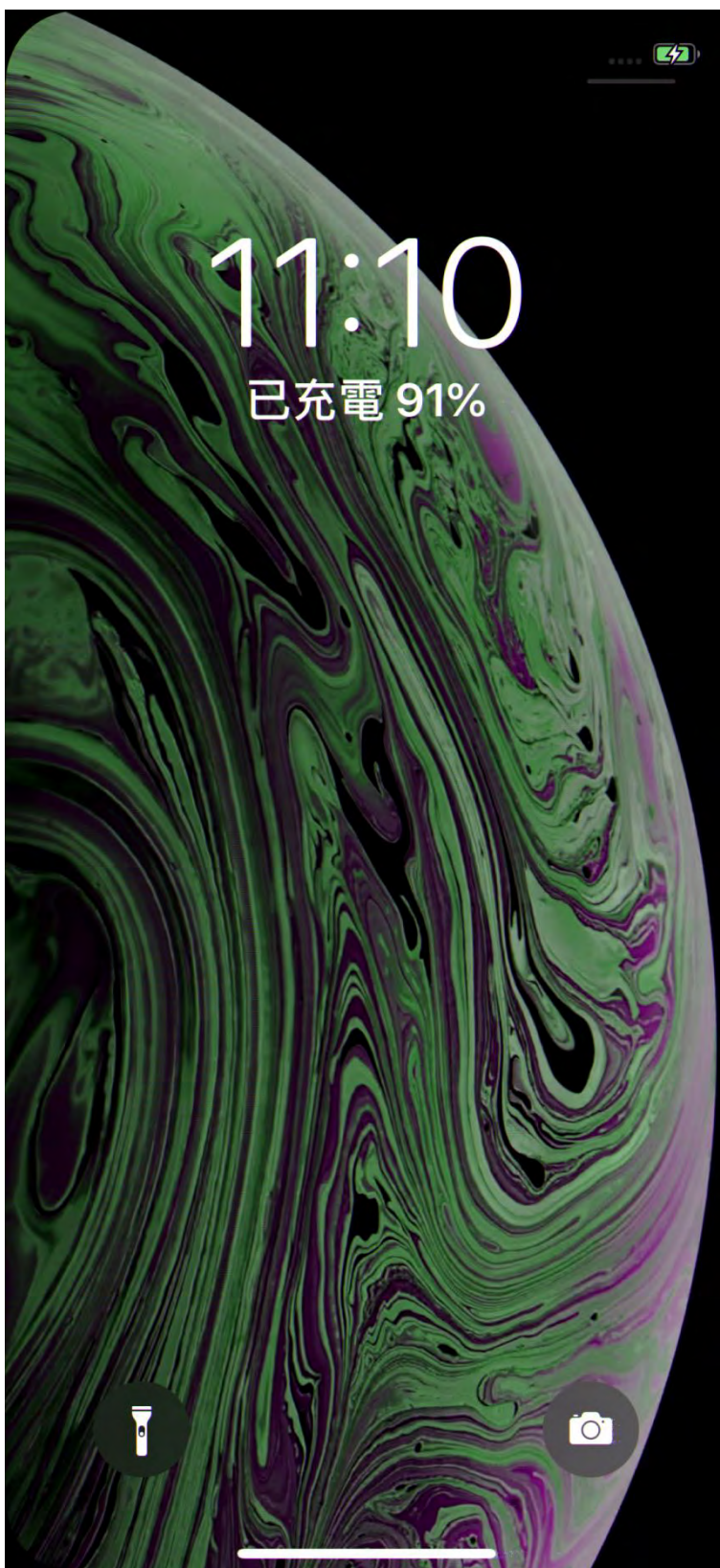

2. CMD mode – 1125 * 2436

